

## Technical Manual Energy Recovery Ventilator

### Models:

CM150-GLRV-220  
CM250-GLRV-220  
CM350-GLRV-220  
CM500-GLRV-220  
CM650-GLRV-220  
CM800-GLRV-220

CM1000-GLRV-220  
CM1300-GLRV-220  
CM1500-GLRV-220  
CM2000-GLRV-220  
CM2600-GLRV-220



### Attention























Please read this manual carefully before using the equipment  
Beijing Holtop Air Conditioning Co., Ltd.

# Contents

Safety Considerations-----	3,4
Unit Specifications-----	5,6
Installation Considerations-----	7,8,9,10
Electrical Installation-----	11
Wiring Diagram-----	12,13
Commissioning Information-----	14
Controller Instruction-----	15 to 24
Dial Switch-----	25
Maintenance -----	26







# Safety Considerations







Please read the following safety instructions before installation. And ensure that the unit is installed correctly.  
Please observe all instruction in order to avoid any injury or damage to equipment or property.

Safety attentions			
The following symbols indicate potential levels of caution.			
 Warning	Situations with a risk or death or serious injure.	 Attention	Situations with a risk of injury or equipment/property damage.
The following symbols indicate compliance which must be observed			
	Not allowed or Stop		Must follow  or obliged
 <b>Warning</b>			
	Installation to be carried out by qualified person, End Users must not install, move or re-install this equipment by themselves		An anti-bird net or similar device should be installed to outside vents. Ensure there are no obstructions to or in the ducts
	Installation engineers must follow this manual strictly. Improper action can create a health hazard and reduce efficiency of the unit		Fresh air vent must be far enough away from any flue gas discharge or areas where hazardous vapors are present
	Unit must be installed strictly following this manual and mounted to a weight bearing surface for the weight of the unit		Electric engineering must follow national regulations and the manual, use special cables. Less capacity cables and improper engineering can cause electric shock or fire.
	During maintenance or repair, the unit and circuit breaker must be switched off. Otherwise electric shock could occur.		Ground wire cannot be connected to gas pipe, water pipe, lighting rod or telephone line etc. Incorrect grounding can cause electric shock.
 <b>Attention</b>			
	Power cable and wires must be installed by a qualified electrical engineer. Improper connection can cause over heating. Fire and loss of efficiency.		To avoid condensation, insulation should be fitted to fresh air ducts. Other ducting may also require insulation depending on dew point conditions.
	Insulation between the metal ducting and wall penetration must be installed if the ducting penetrates metal wall cladding, to avoid risk of electric shock or current leakage.		The cover of wiring box must be pressed down and closed to avoid dust and dirt entering. Excess dust and dirt can cause over-heating of terminals and result in fire or electric shock.
	Use only approved installation hardware and accessories. Failure to observe can result in fire risk, electric shock and equipment failure		Where the unit is positioned, at high level in a hot humid situation. Please ensure sufficient ventilation is available
	The outdoor ducts must be installed facing downwards to avoid rain water entering. Improper installation can cause water leakage.		Correctly sized MCB must be fitted to the unit suitable earth leakage protection should also be installed to avoid risk of electric shock or fire.

# Safety Considerations

## Safety Considerations

 <b>Attention</b>			
	Do not install the unit in an extremely humid conditions, as it may result in electric shock and pose a fire risk.		Do not use the units as the primary kitchen extract grease and fatty deposits can block the heat exchanger, filter and pose a fire risk.
	Don not install the unit in areas there any poisonous or caustic gases are present.		Do not install the unit near open flame as it may result in over heating and pose a fire risk
	Acidic or alkali environments can cause poisoning or a fire		Rated supply voltage must be maintained, otherwise this may cause fire.

 <b>Warning</b>			
	This appliance can be used by children aged from 8 years and above and persons with reduced physical, sensory or mental capabilities or lack of experience and knowledge if they have been given supervision or instruction concerning use of the appliance in a safe way and understand the hazards involved.		
	Children shall not play with the appliance.		Cleaning and user maintenance shall not be made by children without supervision.
	Means for disconnection must be incorporated in the fixed wiring in accordance with the wiring rules.		Prior to cleaning or other maintenance, the appliance must be disconnected from the supply mains.

# Specifications

Model	CM150-GLRV-220	CM250-GLRV-220	CM350-GLRV-220	CM500-GLRV-220	CM650-GLRV-220	
<b>Performance</b>						
Airflow(m <sup>3</sup> /h)	150	250	350	500	650	
Airflow (l/s)	42	70	97	139	180	
Enth. Eff (%)	Cooling	60-65	62-71	62-70	63-72	60-67
	Heating	63-70	65-73	65-73	67-75	65-71
Temp. Eff (%)	75-80	73-81	74-82	76-84	74-82	
Noise Db(A)	31.5	34.5	37.5	39	41	
Power Supply	220~240V/1Ph/50Hz					
<b>Input Power (W)</b>	38	85	107	140	160	
Power Cable	2x1.5mm <sup>2</sup>					
Control Cable	2x0.5mm <sup>2</sup>					
Control	Standard	Yes (7-Day Time-clock)				
	(BMS) Modbus	Yes				
Fan Type	BLDC Fan Motors					
Fan Speeds (Supply)	10 Speed Fan Control					
Fan Speeds (Exhaust)	10 Speed Fan Control					
Summer Bypass	Yes (Automatic with adjustable range)					
Defrost	Yes (Automatic with adjustable range)					
CO <sub>2</sub> Control	Optional sensor (On / Off control with adjustable range)					
Fan Boost Contacts	Yes (1x available connections to Volt-Free contacts: Close= boost to High Speed)					
Fire Shutdown	Yes (1x available connection to Volt-Free contacts: Closed = Shutdown)					
Night free cooling	Yes (1x available connection to Volt-Free Contact: Closed= Bypass open and boost to high speed)					
Weight (Kg)	25	27	33	38	62	
Size (WxHxD)	736*580*264	814*599*270	814*804*270	894*904*270	1186*884*388	
Duct Size	150	150	150	200	250	

# Specifications

Model		CM800-GLRV-220	CM1000-GLRV-220	CM1300-GLRV-220	CM1500-GLRV-220	CM2000-GLRV-220	CM2600-GLRV-220
<b>Performance</b>							
Airflow(m <sup>3</sup> /h)		800	1000	1300	1500	2000	2600
Airflow (l/s)		222	278	360	417	555	722
Enth. Eff (%)	Cooling	63-71	60-68	58-71	63-71	60-68	58-66
	Heating	65-73	62-72	59-75	65-73	62-72	59-75
Temp. Eff (%)		76-82	76-82	74-82	76-80	76-82	74-82
Noise dB(A)		42	43	43	50	51.5	55
Power Supply		220~240V/1Ph/50Hz					
Input Power (W)		188	312	405	700	724	810
Power Cable		2x1.5mm <sup>2</sup>					
Control Cable		2x0.5mm <sup>2</sup>					
Control	Standard	Yes (7-Day Time-clock)					
	(BMS) Modbus	Yes					
Fan Type		BLDC Fan Motors					
Fan Speeds (Supply)		10 Speed Fan Control					
Fan Speeds (Exhaust)		10 Speed Fan Control					
Summer Bypass		Yes (Automatic with adjustable range)					
Defrost		Yes (Automatic with adjustable range)					
CO <sub>2</sub> Control		Optional sensor (On / Off control with adjustable range)					
Fan Boost Contacts		Yes (1x available connections to Volt-Free contacts: Close= boost to High Speed)					
Fire Shutdown		Yes (1x available connection to Volt-Free contacts: Closed = Shutdown)					
Weight (Kg)		72	81	81	147	167	190
Size (WxHxD)		1186*1134* 388	1199*1216* 388	1199*1216* 388	1186*884*7 85	1186*1134* 785	1499*1216* 785
Duct Size		250	250	250	/	/	/

# Installation Considerations

## Dimensions

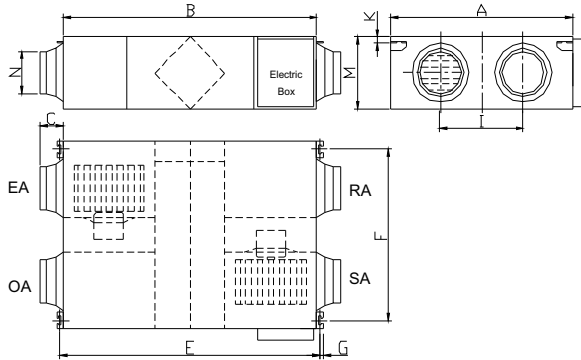

CM150-GLRV-220

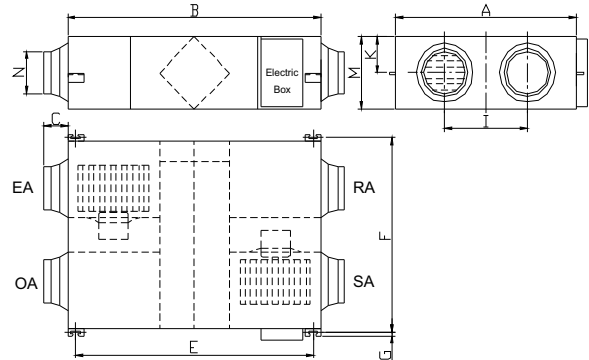

CM250-GLRV-220 - CM1300-GLRV-220

Model	A	B	C	E	F	G	I	K	M	N
CM150-GLRV-220	580	736	100	795	510	19	290	20	264	Φ144
CM250-GLRV-220	599	814	100	745	657	19	315	111	270	Φ144
CM350-GLRV-220	804	814	100	745	862	19	480	111	270	Φ144
CM500-GLRV-220	904	894	107	824	960	19	500	111	270	Φ194
CM650-GLRV-220	884	1186	85	1115	940	19	428	170	388	Φ242
CM800-GLRV-220	1134	1186	85	1115	1190	19	678	170	388	Φ242
CM1000-GLRV-220	1216	1199	85	1130	1273	19	621	171	388	Φ242
CM1300-GLRV-220	1216	1199	85	1130	1273	19	621	171	388	Φ242

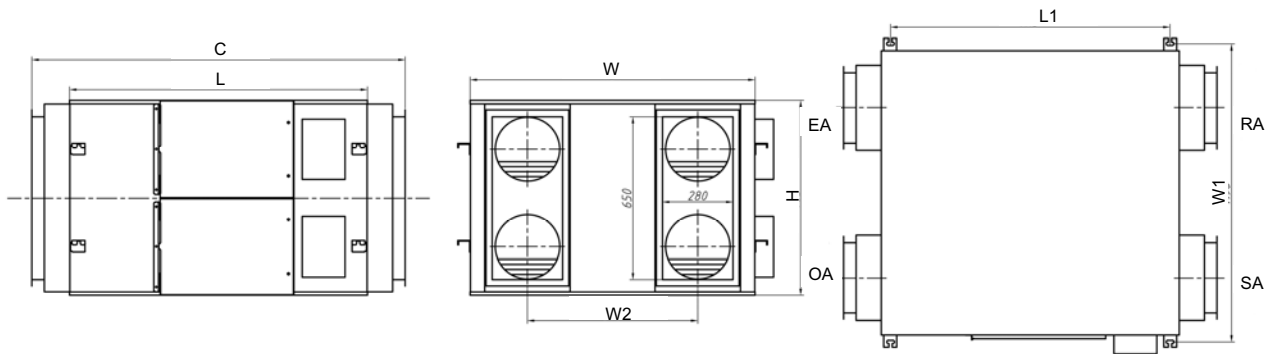

CM1500-GLRV-220 - CM2600-GLRV-220

Model	C	L	L1	W	W1	W2	H
CM1500-GLRV-220	1486	1186	1115	884	940	428	785
CM2000-GLRV-220	1486	1186	1115	1134	1190	678	785
CM2600-GLRV-220	1499	1199	1130	1216	1273	760	785

# Installation Considerations

## Installation Considerations

Protect the unit to avoid dust or other obstructions entering the unit and accessories during installation, or whilst in storage on site. Service ports should be installed to allow access for filter maintenance.

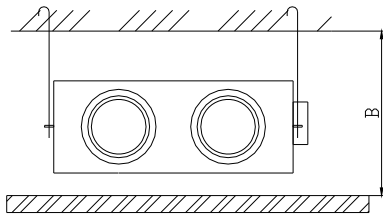
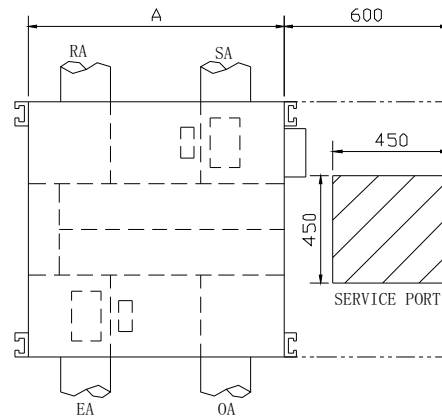
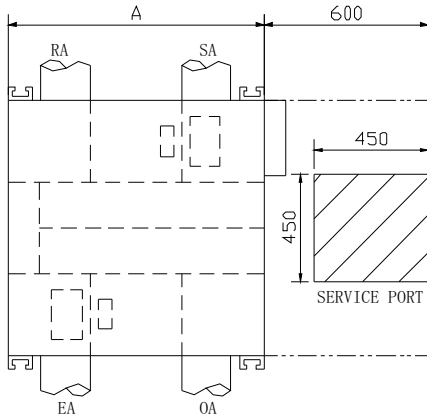

Model	A	Inner ceiling height B
CM150-GLRV-220	580	320

Model	A	Inner ceiling height B
CM250-GLRV-220	599	320
CM350-GLRV-220	804	320
CM500-GLRV-220	904	320
CM650-GLRV-220	884	450
CM800-GLRV-220	1134	450
CM1000-GLRV-220	1216	450
CM1300-GLRV-220	1216	450
CM1500-GLRV-220	884	835
CM2000-GLRV-220	1134	835
CM2600-GLRV-220	1216	835



# Installation Considerations

## Installation Diagram

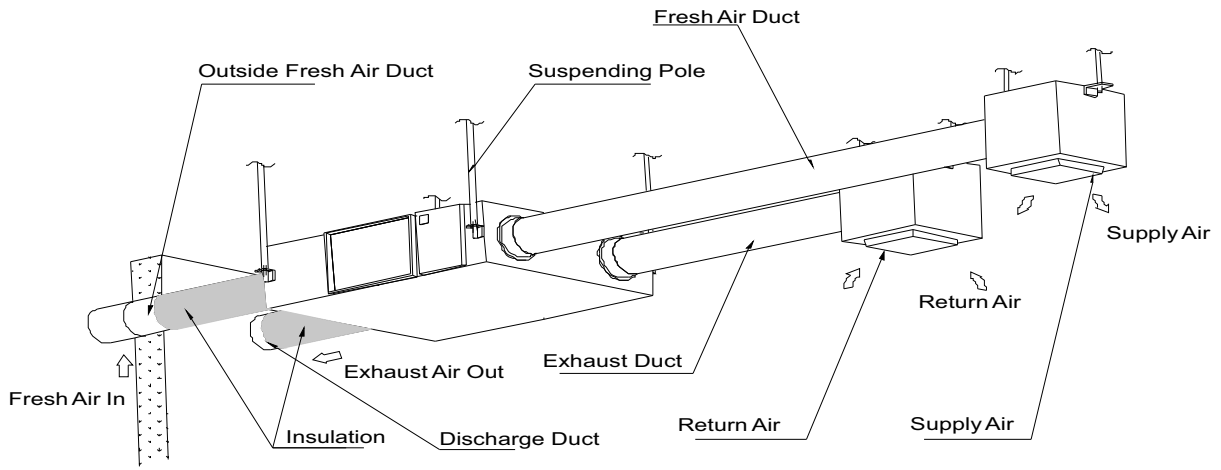

## Physical Installation

1. Installer to prepare suitable threaded hangers with adjustable nuts and gaskets.
2. Install as shown by the image above. Installation must be level and securely fastened.
3. Failure to observe proper fixing could result in injury, equipment damage and excessive vibration. Uneven installation will also effect damper operation.

Notes for reverse installation of the unit

4. Reverse labeling shows the unit is upside down.

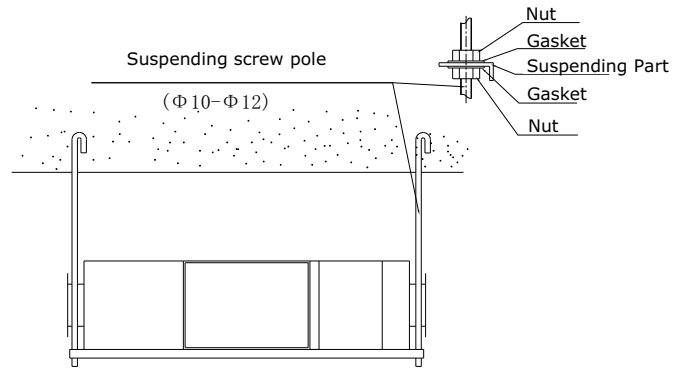

## Ducting

1. Connection of unit vents and ducts should be taped or sealed to prevent air leakage, and should comply to relevant guidelines and regulations.
2. The two outdoor vents should face downward toward the outside to prevent any rain water ingress. (angle 1/100 1/50).
3. Insulation must be with the two ducts outside to prevent condensation.

Material: glass cotton, Thickness: 25mm

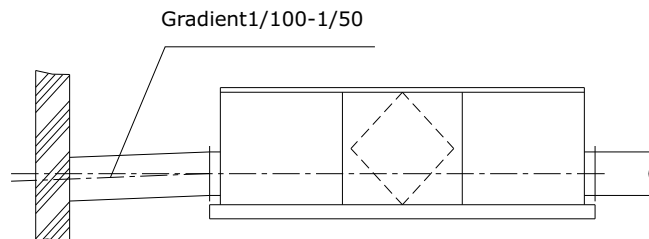

# Installation Considerations

1. Be sure the ceiling height is no less than the Figures in above table B column.
2. Unit must not be installed close to boiler flues.
3. Following phenomenon should be avoided in the ducting installation.

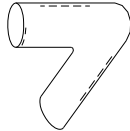

Severe bends

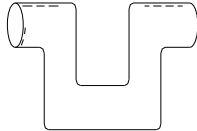

Multiple direction changes



Multiple reducers/ crimped duct

4. Excessive use of flex-duct and long flex-duct runs should be avoided.
5. Fire dampers must be fitted as per national and local fire regulations.
6. Unit must not be exposed to ambient temperature above 40C and should not face an open fire.
7. Take action to avoid dew and frost.

As shown by drawing below, unit will produce dew or frost when saturation curve is formed from A to C. Use pre-heater to ensure conditions are kept to right of the curve (B to B' , to move C to C) to prevent condensation or frost formation.

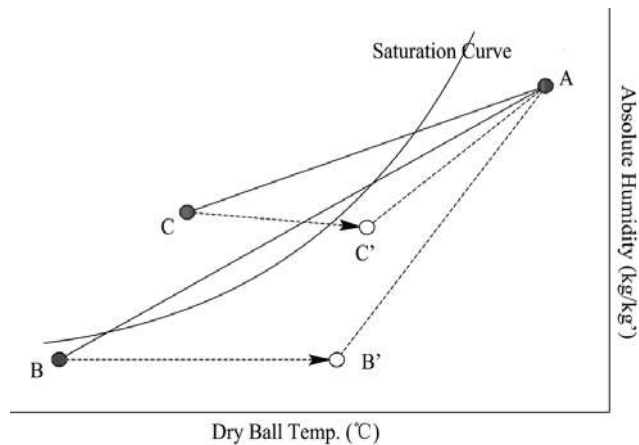

8. To avoid the outdoor exhaust air cycling back to indoor, the distance between the two vents installed on the outside wall should be over 1000mm.
9. If heater is equipped to the unit, operation of heater should be synchronous with the unit, so that the heater starts to work only when unit starts.
10. Duct muffler may be considered if user wants indoor noise to be minimized.

# Electrical Installation



Power must be isolated during installation and before maintenance to avoid injury by electric shock. The specifications of cables must strictly match the requirements, otherwise it may cause performance failure and danger of electric shock or fire.

Power supply is AC220-240V/50HZ/1 Phase. Open the cover of electrical box, connect the 2 wires (L/N/) to the terminals and connect the cable of the control panel to the board according to the wiring diagram, and join the control panel to the cable. A cable fixing device offered by installer is recommended to fix the power cable on the wall/ventilator.

Model	Spec. of power supply cable	Spec. of normal controller cable
CM150-GLRV-220	2×1.5mm <sup>2</sup>	2×0.5mm <sup>2</sup>
CM250-GLRV-220		
CM350-GLRV-220		
CM500-GLRV-220		
CM650-GLRV-220		
CM800-GLRV-220		
CM1000-GLRV-220		
CM1300-GLRV-220		
CM1500-GLRV-220		
CM2000-GLRV-220		
CM2600-GLRV-220		



We do not accept any liability for any problems caused by the user's self and non-authorized re-engineering to the electrical and control systems.





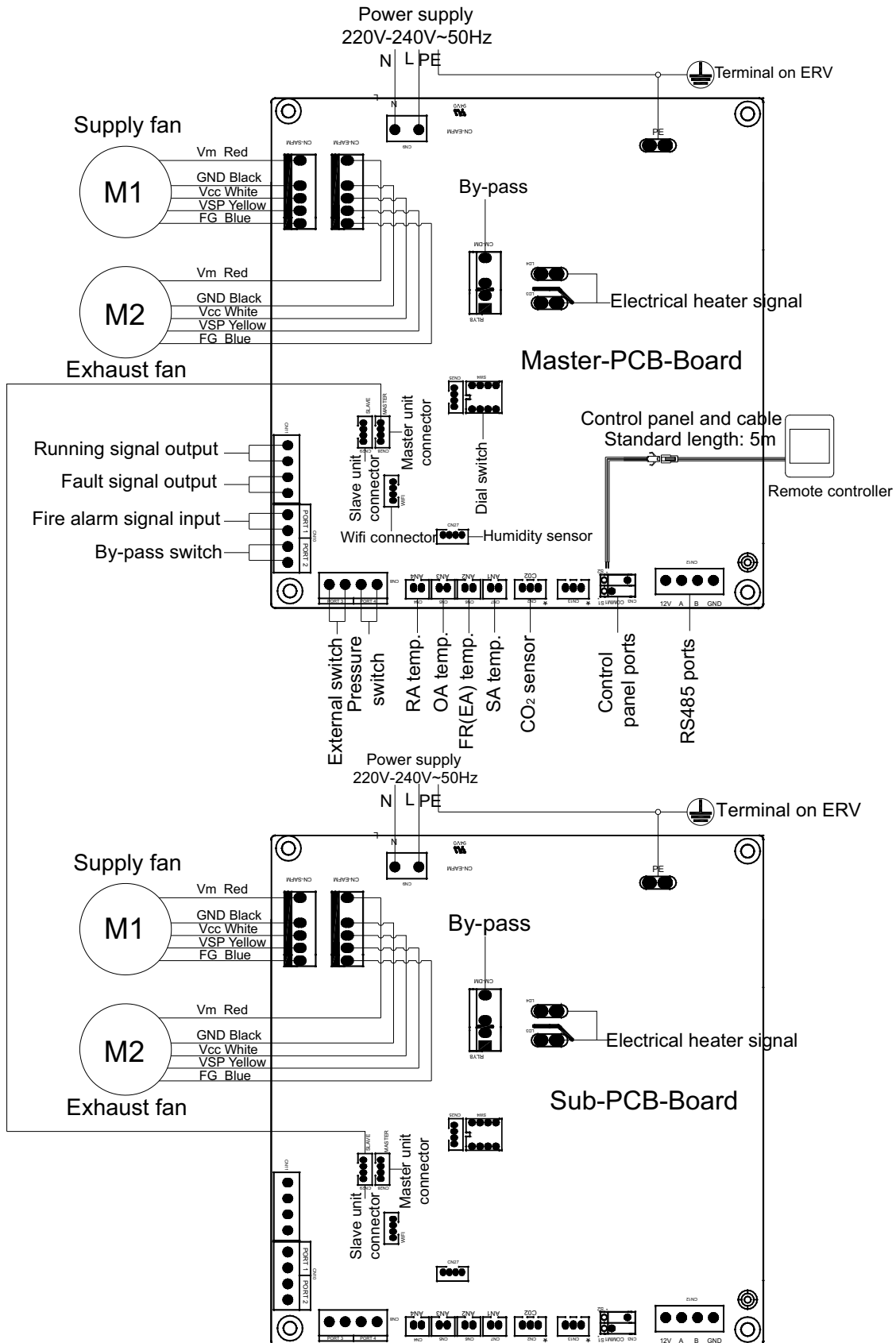

# Wiring Diagrams

## CM1500-GLRV-220 - CM2600-GLRV-220





























# Commissioning

Check that all cable sizes, circuit breakers and wire connections are correct before following below commissioning steps:

1. Press button  to turn on/off the ventilator.
2. Match the correct speed to ERV. Press  for 6 seconds to enter parameters setting and at this time the parameter number is shown in the middle of the screen, press button  to switch to parameter No. 21 (refer to parameters list in commissioning page) then press  shortly to enter the parameter setting, default value "0" flashes at the top right corner, press UP and DOWN buttons to change the value according to below table (ERV code Vs Models) then press button  again to confirm setting. With the same way to change parameters number 23 to be value 2 (10 speeds DC fan control)

Code	Models	Code	Models
15	CM150-GLRV-220	11	CM650-GLRV-220
14	CM250-GLRV-220	12	CM800-GLRV-220
13	CM350-GLRV-220	12	CM1000-GLRV-220
13	CM500-GLRV-220	11	CM1300-GLRV-220
11	CM1500-GLRV-220	12	CM2000-GLRV-220
11	CM2600-GLRV-220		

3. Then check the mode and fan speed switch. Press button  shortly to switch to OA, RA, SA or EA mode, check whether the temperature of the corresponding mode is correct. Under SA or RA mode, Press   to switch the fan speed, check if the airflow is adjusted corresponding to H speed  speed  and L speed .
4. Check the operation of bypass. The default opening temperature of bypass is 19-21C (adjustable), press button  to check the temperature of OA. If the present OA temperature is among 19-21C, then bypass will open automatically. If the OA temperature is not within 19-21C, say 18C, then press button  more than 6 seconds to enter the parameter setting. Press  button to switch to parameter number 02, default value 19 flashes shown at the top right corner, Then press  button shortly to enter setting, by pressing   buttons and set the value to be "X", "X" should be less than 18C (present OA temperature), then press  again to confirm. with the same way to set parameter number 03 value to be "Y", if "X" < OA temperature < "X+Y". then bypass will open automatically, after bypass open, user can adjust the values under parameters 2 and 3 to make OA < "X" or OA > "X+Y", then bypass will close automatically, please pay attention that bypass open/closed will be around 1 minute delayed.

 <b>Warning</b>	
 Loose or incorrect wiring connection can cause explosion or fire when the unit starts to work. Use only rated power voltage.	 Don't put fingers or objects into vents of fresh air or exhaust air supply. Injury may be caused by the rotation of the impeller.
 Don't install, move or re-install the unit by yourself. Improper action may cause unit instability, electric shock or fire.	 Don't change, disassemble or repair the unit by yourself. Improper action may cause electric shock or fire.
 Running the unit continuously in an abnormal status may cause failure, electric shock or fire.	 Switch off the power and breaker when you clean the exchanger.
 <b>Attention</b>	
 Don't site intake supply vent in hot and humid conditions, as it may cause failure, current leakage or fire.	 Don't put any burner directly facing the fresh air discharge, otherwise it may cause an insufficient burning.
 Isolate power during extended off periods. Isolate power and take care when cleaning unit. (Risk of electric shock)	 Observe guidelines and regulations relating to incomplete combustion when use is associated with fuel burning appliances.
 Clean the filter regularly. A blocked filter may result in poor indoor air quality.	

# Touch Screen Intelligent Controller

## Control Panel

The intelligent controller is surface mounted and comes with a touch screen LCD display screen. Standard connection cable is 5 meters, in case of a longer cable is needed, then please use the shielded cable, to avoid the signal interference which may lead to communication error.

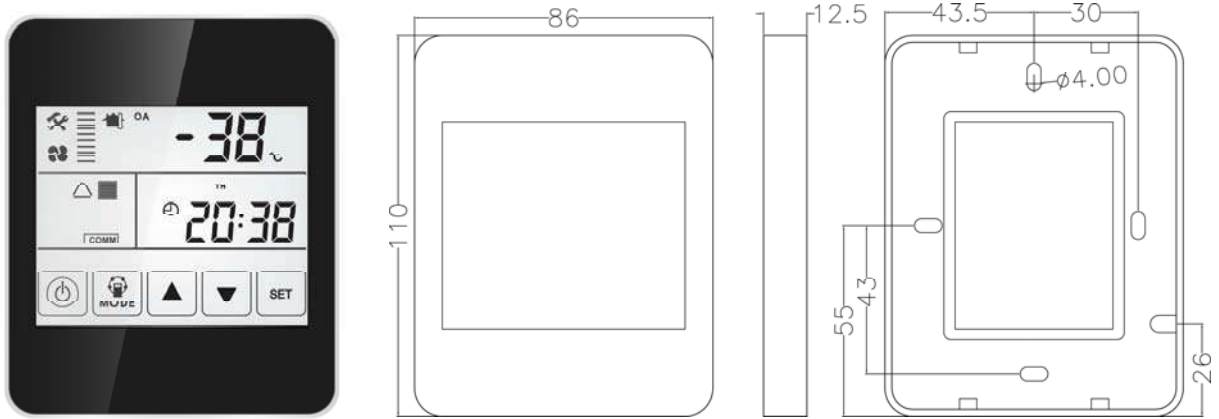

## Display screen and Buttons

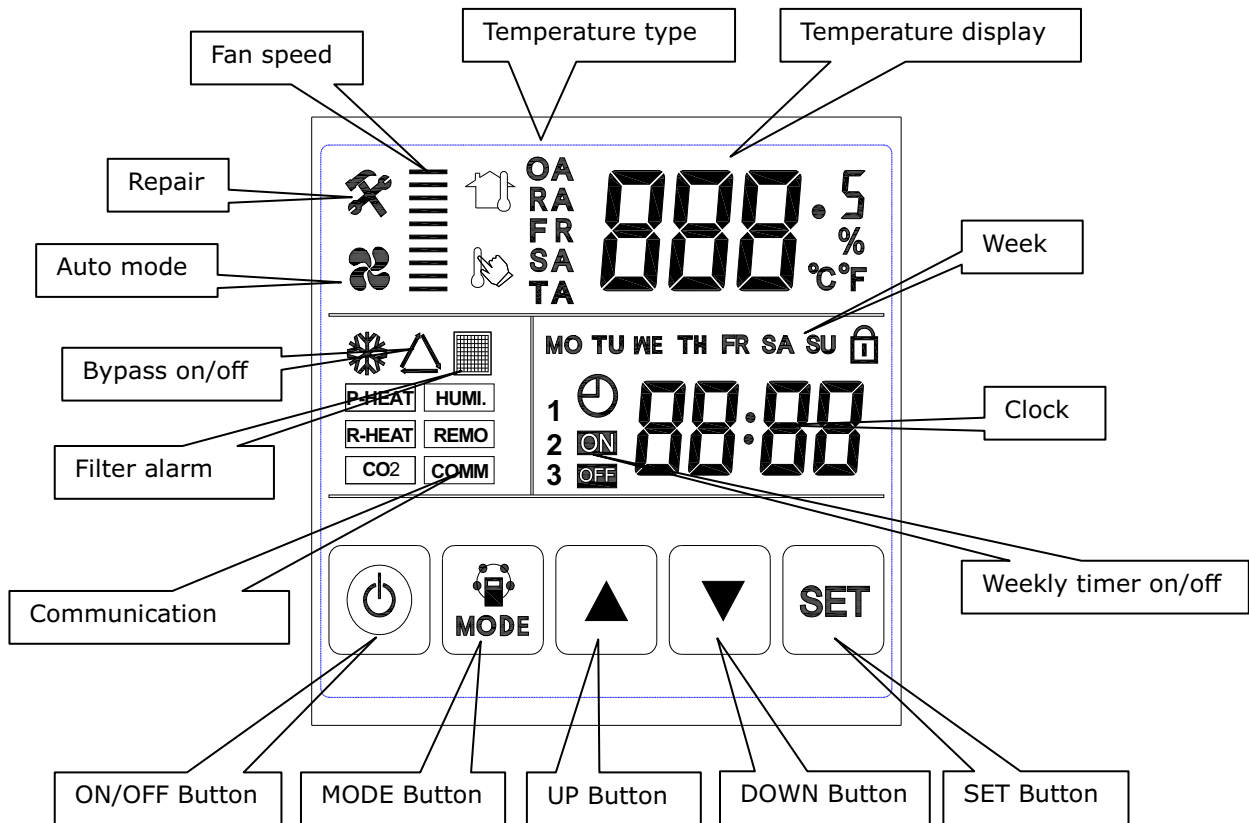

# Touch Screen Controller Instructions

## Operation Instructions

1. ON/OFF: press ON/OFF button once for starting; twice for closing. In ON status, backlit LCD display lights up, in OFF status, backlit LCD display off, without operation for 6 seconds, backlit LCD display off too. By pressing ON/OFF button for around 6 seconds can lock and unlock the controller.

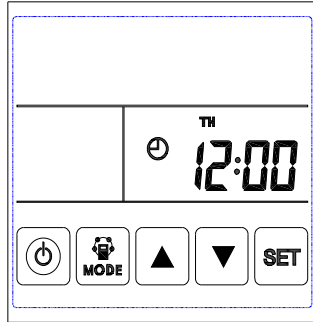

OFF state

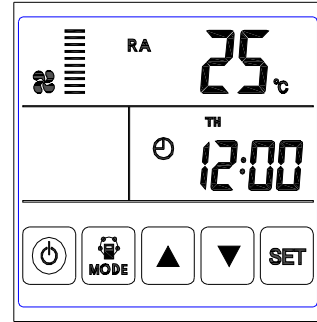

ON state

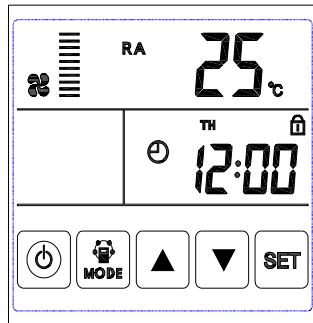

Lock state

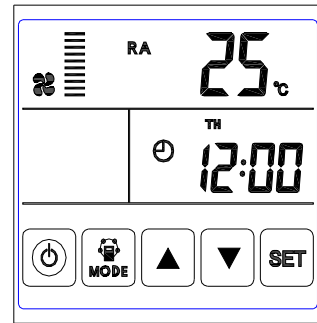

Unlock state

2. Mode switch: press MODE button to choose display the RA-OA-FR(EA)- SA Setting-CO2 status or Humidity control status.

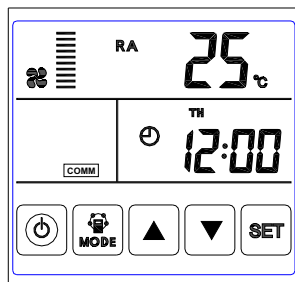

RA temperature

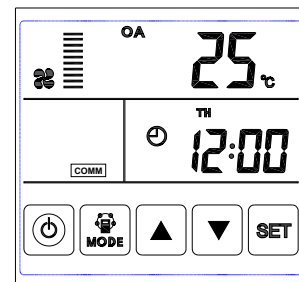

OA temperature

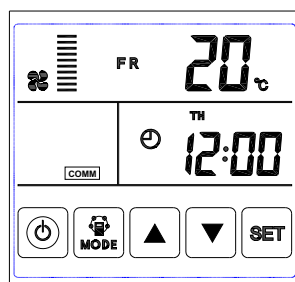

FR temperature

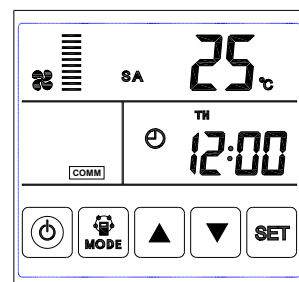

SA temperature



# Touch Screen Controller Instructions

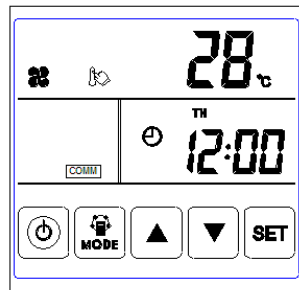

SA temperature setting

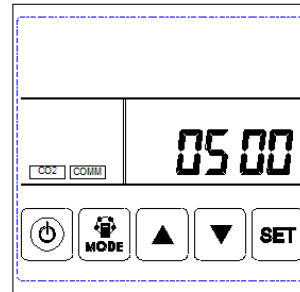

CO2 concentration

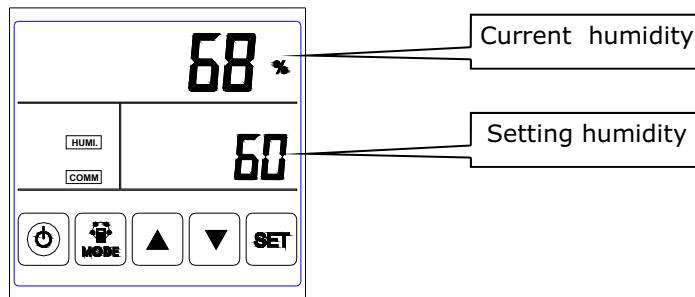

Humidity control

## Remark:

1) Under SA setting mode, after connecting the electrical heater to the PCB (LD3 and LD4) and change parameter 01 to value 1, users can set the supply air temperature by pressing up and down button. The setting temperature range is 10-25°C:

- A)  $0^{\circ}\text{C} < \text{setting temperature minus SA temperature} < 5^{\circ}\text{C}$ , 1st stage heater on, 2nd stage heater off
- B) Setting temperature minus SA temperature  $> 5^{\circ}\text{C}$ , 1st and 2nd stage heater on

2) The CO2 symbol appears when the CO2 sensor is connected. ERV runs at boost speed when CO2 concentration higher than setting value.

3) The humidity symbol appears when the "temperature and humidity sensor" is connected. ERV runs at boost speed when humidity higher than setting value.

Under "humidity control" mode, users can set the setting humidity by pressing up and down button. The setting range is 45% ~ 90%. And the Dial switch SW4-3 on the PCB should be switched ON to switch from CO2 control function to humidity control function.

3. Air volume setting: Under SA or RA temperature interface. Users can set the return air volume in "RA" status, and set the supply air volume in "SA" status by pressing up and down button. Totally 10 speeds control.

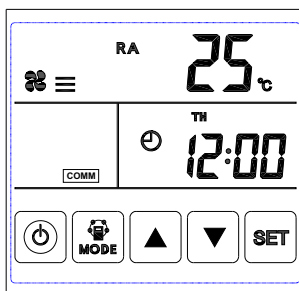

Speed 3

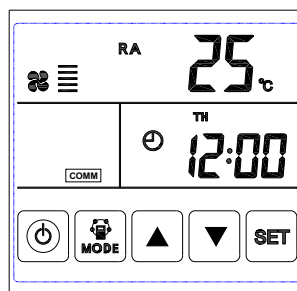

Speed 5

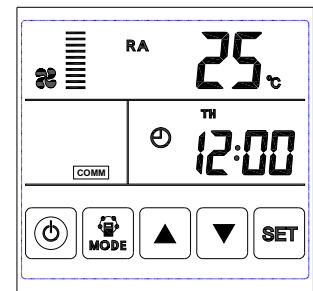

Speed 10

# Touch Screen Controller Instructions

4. Error code checking: under the main interface, press the SET button for short, user can check the error code of ventilator, refer to below table.

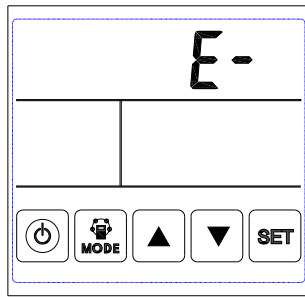

No Error

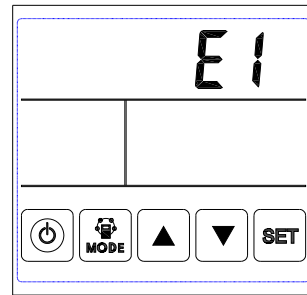

Error alarm

Code	Error
E1	Fresh air temperature sensor error
E2	EEPROM error
E3	Return air temperature sensor error or SW4-3 is in On position but without connecting to the humidity sensor
E4	Exhaust air temperature sensor error
E5	Communication error
E6	Supply air temperature sensor error
E7	Exhausted fan error
E8	Supply fan error

5. Bypass setting: when bypass is on, the triangle bypass symbol appears, when bypass is off, the symbol disappears, please refer to page 15 commissioning part for the detailed setting introduction.

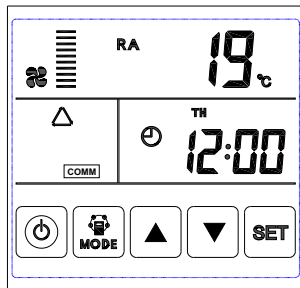

Bypass on

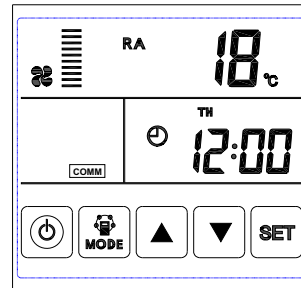

Bypass off

6. Filter alarm:

1) Timer alarm: When running time of ventilator is over the setting filter alarm time, the filter alarm symbol flashes to remind user clean/replace the air filters. After filters being cleaned/replaced, please sweep the filter alarm by setting parameter Number 24, value 1.

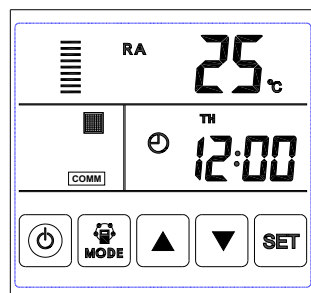

Filter alarm on

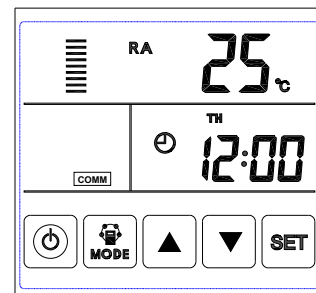

Filter alarm off

# Touch Screen Controller Instructions

2) Pressure switch alarm, the switch is installed on the access door to monitor the F9 filter, once the pressure difference is larger than the setting value, then the switch will transmit dirty filter signal to the control system, filter alarm symbol on the LCD display flashes to remind customer to replace the filter.



Pressure switch



**Attention:**

- 1) As showed by the above pictures, open the plastic cover and use the “—” screwdriver to set the correct pressure difference.
- 2) Pressure switch is installed by manufacturer ex-factory, it is wired to the PCB PORT 4, there is no wiring sequence of PORT 4. For the details please refer to the wiring diagram on page 12.

7. Parameters setting: Keep pressing the MODE button for 6 seconds, after buzzing to enter the parameter setting interface.

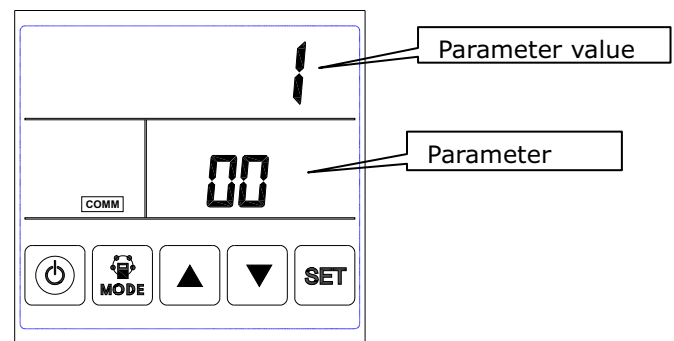

After entering the parameter setting interface, press SET button shortly to change the parameter number, every pressing will make parameter value +1. After choosing the correct parameter number, press Mode button for short, parameter value flashes at the top right corner, at this time to change the value by UP and DOWN buttons. After parameters setting then press SET button to save.

**Attention:**

- 1) After parameters setting, system need around 15 seconds to record, during this period power should not be off.
- 2) Please refer to below parameters table to set the suitable parameters according to different requests.

No.	Contents	Range	Default	Unit	Record Position
00	Power to auto restart	0-1	1		Main control
01	Electrical heater available	0-1	0		Main control
02	Bypass opening temperature X	5-30	19	°C	Main control
03	Bypass opening temperature range Y	2-15	3	°C	Main control
04	Defrosting interval	15-99	30	Minute	Main control
05	Defrosting entering temperature	-9-5	- 1	°C	Main control
06	Defrosting duration time	2-20	10	Minute	Main control
07	CO2 sensor function value	00, 80-250	00 (off)	X10 PPM	Main control
08	Modbus ID address	1-16	1		Main control
21	ERV models match/selection	0-7	0		Main control
23	Fan speed control	0: 2 speeds 1: 3 speeds 2: 10 speeds (DC)	2		
24	Multifunction setting	0: Reserved 1: Sweep filter alarm 2: sweep weekly timer	0		
25	Filter alarm setting	0: 45 days 1: 60 days 2: 90 days 3: 180 days	0	Main control	

# Touch Screen Controller Instructions

## Instruction of Parameter Settings

1) Parameter 00 refers to power to auto restart  
0: Invalid, 1: Valid

2) Parameter 01 refers to Supply air electrical heater function  
0: Not available 1: Available

When connecting with supply air electrical heater, user should choose 1 to activate the electrical heater, and under the SA temperature setting interface, the SA temperature can be set by pressing up and down button. The setting temperature range is 10-25°C.

3) Parameter 02-03 refers to automatic bypass function

The bypass is opened on the condition that the outdoor temperature is equal or higher than X (parameter 02) and less than X+Y (parameter 03). Bypass is closed on other conditions.

4) Parameter 04-06 refers to automatic defrost function

When EA side of heat exchanger temperature lower than -1°C (defrosting entering temperature, parameter 05) and last for 1 minute, and the interval of defrosting is longer than 30 minutes (parameter 04), the exhaust fan will run at high speed automatically for defrosting, and supply fan will stop, until EA side temperature higher than defrosting entering temperature +15°C for 1 minute, or the defrosting time is longer than 10 minutes (parameter 06).

5) Parameter 07 refers to CO2 concentration control function (optional)

After connecting the optional CO2 sensor, the CO2 symbol will display on the screen. If CO2 concentration is higher than setting value, then ERV runs at high speeds automatically, after CO2 concentration is lower than setting value, then ERV returns back to the previous status (standby, speed 1, 2, 3 etc.), if the ERV is already in highest speed when CO2 concentration higher than setting value, then ERV keeps the highest speed running. CO2 default setting value is 00, which means CO2 function off, setting range is 80-250, which means 800-2500PPM (setting value times 10), recommend PPM is 1000.

6) Parameter 08 refers to the central control function to identify the address of ERV.

7) Parameter 21 to match the suitable program on PCB to the ERV model, refer to below table.

Code	Models	Code	Models
15	CM150-GLRV-220	11	CM650-GLRV-220
14	CM250-GLRV-220	12	CM800-GLRV-220
13	CM350-GLRV-220	12	CM1000-GLRV-220
13	CM500-GLRV-220	11	CM1300-GLRV-220
11	CM1500-GLRV-220	12	CM2000-GLRV-220
11	CM2600-GLRV-220		

8) Parameter 23 refers to the fan speed display, for the ERV with BLDC motor, user should change value to 2 for 10 speed control.

9) Parameter 24 refers to clear filter alarm and weekly timer setting.

10) Parameter 25 refers to set the filter alarm timer.

# Touch Screen Controller Instructions

## 8. Time setting

Keep pressing the SET button for 6 seconds, after buzzing to enter the time setting interface. Under this interface, press the MODE button shortly, then can switch from time setting, day setting, weekly timer on and weekly timer off setting.

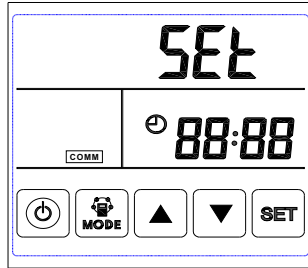

Time setting

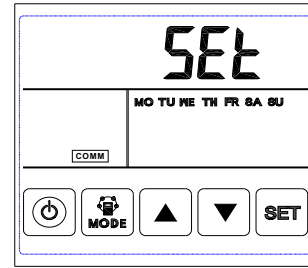

Week setting

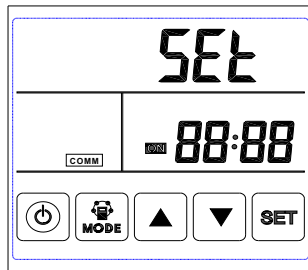

Weekly timer on

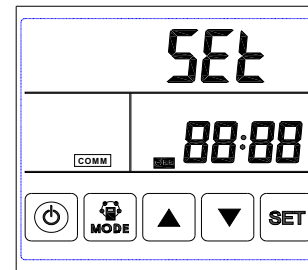

Weekly timer off

A. Time setting: under time setting interface, press SET button for short, at this time "hour" flashes, press UP and DOWN button to change "hour". After setting "hour", press MODE button for short to switch to "minute" setting, at this time "minute" flashes, press Up and Down button to change "minute". After time setting, press SET button to save and return to the main interface.

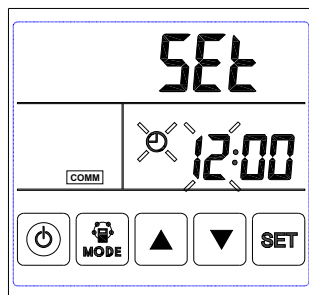

Hour setting

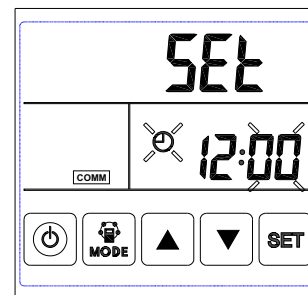

Minute setting

# Touch Screen Controller Instructions

B. Day setting: under day setting interface, press SET button for short to begin the day setting, by pressing UP and DOWN buttons to select the correct day, after this finished, press SET button to save and return to the main interface.

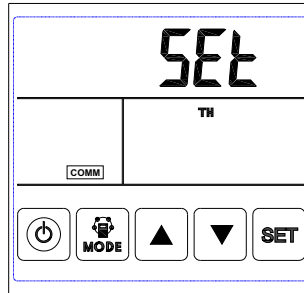

Day setting

C. Weekly timer on setting: under weekly timer on setting interface, press SET button to begin the timer on setting, press SET button time after time to select Monday period 1 to Sunday period 2 (namely Monday period 1 to Sunday period 2).

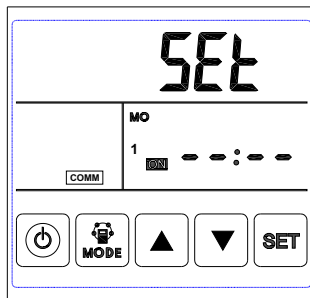

Period 1 timer on

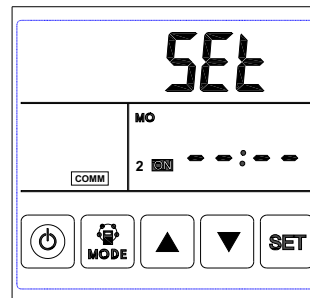

Period 2 timer on

After selecting the day, press ON/OFF button to confirm timer on is valid/invalid.

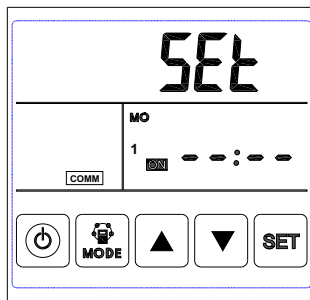

Timer on valid

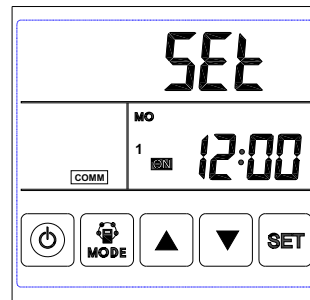

Timer on invalid

When timer on is valid, press MODE button to enter "hour" setting, by pressing UP and DOWN button to set "hour". After "hour" setting, press MODE button to enter "minute" setting. After "minute" setting, press SET button to save and switch to the next day timer on setting, and repeat the above steps to set all days and periods timer on. After setting all the time on, press SET button to save the data.

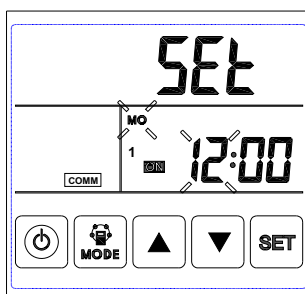

Timer on hour setting

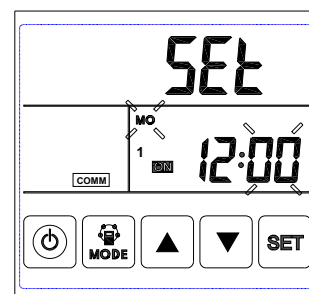

Timer on minute setting

# Touch Screen Controller Instructions

D. Weekly timer off setting: under weekly timer off setting interface, press SET button for short to begin the timer off setting, press SET button time after time to select Monday period 1 to Sunday period 2 (namely Monday period 1 to Sunday period 1 then Monday period 2 to Sunday period 2).

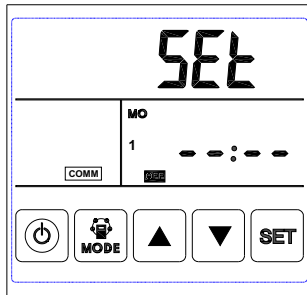

Period 1 timer off

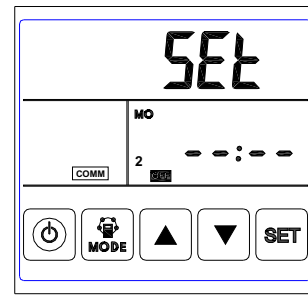

Period 2 timer off

Under the week interface, press ON/OFF button to confirm the timer off is valid/invalid.

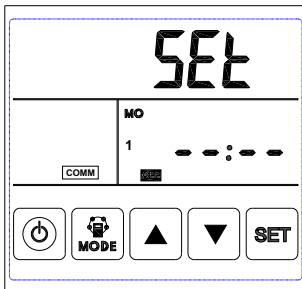

Timer off invalid

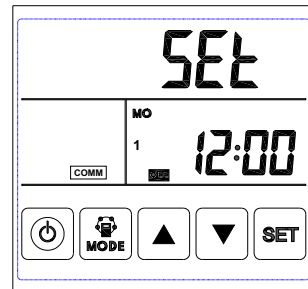

Timer off valid

When timer off is valid, press MODE button to enter "hour" setting, by pressing Up and Down button to set "hour", after "hour" setting, press MODE button to enter "minute" setting, after "minute" setting, press SET button to save and switch to the next day timer off setting and repeat the above steps to set all days and periods timer off. After setting all the timer off, press SET button to save the data.

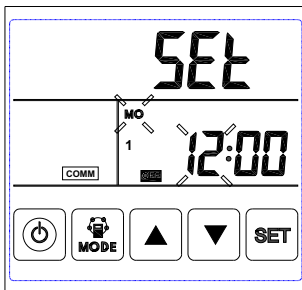

Timer off hour setting

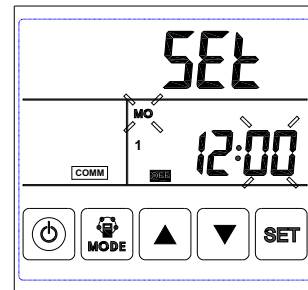

Timer off minute setting

Attention: Under time setting, if no operation for 10 seconds, system will return to the main interface automatically.

# Eco-Smart ModBus Address

Add:	Content	Range	Default	Record
00	Power to auto restart	0/1	1	PCB
01	Heater valid or invalid	0/1	0	Controller
02	Bypass opening temperature X	5-30	19	PCB
03	Bypass opening temperature range Y	2-15	3	PCB
04	Defrosting interval	15-99	30	PCB
05	Defrosting enter temperature	-9 to 5	-1	PCB
06	Defrost duration time	2-20	10	PCB
07	CO2 sensor value setting	24-255 (unit= x10PPM)	0	PCB
08	ModBus address	01-16	01	PCB
09	ERV ON/OFF	0-OFF 1-ON		PCB
10	Supply fan speed	Fan speed: 0=stop, 2=speed 1, 3=speed 2, 5=speed 3, 8=speed 4, 9=speed 5, 10=speed 6, 11=speed 7, 12=speed 8, 13=speed 9, 14= speed 10		PCB
11	Exhaust fan speed	Fan speed: 0=stop, 2=speed 1, 3=speed 2, 5=speed 3, 8=speed 4, 9=speed 5, 10=speed 6, 11=speed 7, 12=speed 8, 13=speed 9, 14= speed 10		PCB
12	Room temperature	observed, showing number minus 40		PCB
13	Outdoor temperature	observed, showing number minus 40		PCB
14	Exhaust air temperature	observed, showing number minus 40		PCB
15	Defrosting temperature	observed, showing number minus 40		PCB
16	External ON/OFF signal	query value, 0=off, 1=on		PCB
17	CO2 ON/OFF signal	query value, 0=off, 1=on		PCB
18	Fire alarm signal/bypass/defrosting signal	query value: B0 - 1-fire alarm ON B1- 1-bypass on B2- 1-bypass off B3- 1- defrosting		PCB
19	Humidity value setting	1-99		PCB
20	Error symbol	query value: B0-OA sensor error, B1-EEPROM error, B2-RA sensor error, B3-EA sensor error B5-SA sensor error, B6-Supply Fan error, B7-Exhaust Fan error		PCB
24	Multifunction Setting	0-Reserved, 1-Filter alarm clear		PCB
25	Filter alarm timer	0-45 days, 1-60 days 2-90 days, 3-180 days		PCB
27	Heater on/off temperature	10-25		PCB
768	CO2 value	PPM		PCB
769	Fan running time record	Unit: 0.1h , range 0-65535		PCB
770	Indoor humidity	1%	PCB	



# Introduction of dial switch

## Introduction of dial switch

### Dial switch

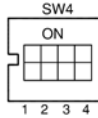

- 1. SW4-1: OFF-Traditional EA fan defrost
- 2. SW4-2: OFF-Auto bypass
- 3. SW4-3: OFF-CO2 sensor
- 4. SW4-4: OFF-Baud rate 4800

- ON-OA side electrical heater defrost
- ON- Bypass function invalid
- ON-Humidity sensor and CO2 sensor
- ON-Baud rate 9600

**Attention: Please cut off the power before dialing.**

1. SW4-1 is switching the defrost mode. Default is "off", it means traditional defrost by EA fan. When turn to "on", the defrost mode is changed to be OA side heater defrost (required to connect the heater to the OA duct, only suggested in winter under  $-15^{\circ}\text{C}$ ), at this time the parameter 01 would be turned to 0 automatically and the supply air side electrical heater is not able to use.

Under electrical heater defrost mode, controller can automatic drive the electric heater on/off to heat the fresh air in order to prevent frosting at the EA side of heat exchanger.

- 1) If the outdoor fresh air temperature  $< -15^{\circ}\text{C}$ , the OA heater turns on for 50 minutes, then the ventilator switches off for 10 minutes and restarts.
- 2) If the OA heater switches on and the exhaust air temperature still  $< -1^{\circ}\text{C}$ , then the ventilator will stops for 50 minutes.
- 3) If the exhaust air temperature  $< -1^{\circ}\text{C}$  and the outdoor air temperature  $> -15^{\circ}\text{C}$ , the OA heater switches on for 10 minutes for defrosting.
- 4) If the OA heater is on and temperature of outdoor air is  $> +25^{\circ}\text{C}$ , then OA heater will stop for 5 minutes, If the outdoor air temperature is detected over  $25^{\circ}\text{C}$  by sensor over 3 times, electrical heater stops.

2. SW4-2 is the bypass function control, off=auto bypass, on=bypass function invalid.

3. SW4-3 is switching the forced ventilation mode. Default is "off", it means that ventilator is controlled by CO<sub>2</sub> sensor. When turn to "on", the ventilator is controlled by both humidity sensor and CO<sub>2</sub> sensor, if SW4-3 turned to "ON" but without connecting humidity sensor, then E3 error code appears.

4. SW4-4 is baud rate switch, off=4800, on=9600.

### External voltage free connectors on the PCB

1) Running signal output (switch): by connecting external device and external power supply to this device, when ventilator runs, then this device turns on automatically, when ventilator stops, then this device turns off automatically.

2) Fault signal output (switch): by connecting external lamp and external power supply to this lamp, when ventilator is normal, the lamp is off, when the ventilator has error, then the lamp turns on (for error reminding purpose)

3) Fire alarm signal input (switch), buy connecting a smoke sensor and a A/C contractor (or a relay) to this connector, when smoke sensor activated and let the A/C contractor (or relay) to close this connector, then ventilator turns off.

4) Bypass switch: refer to below table

SW4-2 OFF	The ventilator is off	The ventilator is on
Connector closed	Bypass open, ERV in boost speed	Bypass open, ERV in boost speed
Connector open	Auto bypass, ventilator off	Auto bypass, same speed as it was
SW4-3 ON	The ventilator is off	The ventilator is on
Connector closed	Bypass invalid, ERV in boost speed	Bypass invalid, ERV in boost speed
Connector open	Bypass invalid, ERV off	Bypass invalid, same speed as it was

5) External switch: Interlock with restroom, bathroom, etc, which need function of one button to boost speed. or external devices like air conditioner to interlock with ERV system. Once this connector is closed, ventilator turns to boost speed, when this connector is open, then ventilator returns to previous working conditions (1-9 speeds or standby status), if the ventilator is in boost speed when this connector closes, then it remains the boost speed.

# Maintenance

## Warning

Power must be isolated before installation and maintenance to avoid injury or electric shock. Supply power cables, main circuit breaker and earth leakage protection, must comply with national regulations. Failure to observe could cause unit failure, electric shock or fire.

Standard filtration is supplied with this unit and must be used. Dust and dirt can accumulate in the heat exchanger if filters are removed. (This can lead to failure or decreased performance). To ensure efficient operation, regular cleaning or replacement of filters is required. Filter maintenance frequency will depend on working environment and unit running time.

### Cleaning the filter

1. Open the access door
2. Remove the filters (from the side of the unit)
3. Vacuum the filters to get rid of the dust and dirt. For bad conditions dip it into water with soft wash to clean. Note: F9 filter is no washable.
4. Push the filters to the positions after they get dried naturally, close the access door.
5. Change the filters if they are badly affected with dust and dirt or if they are broken.

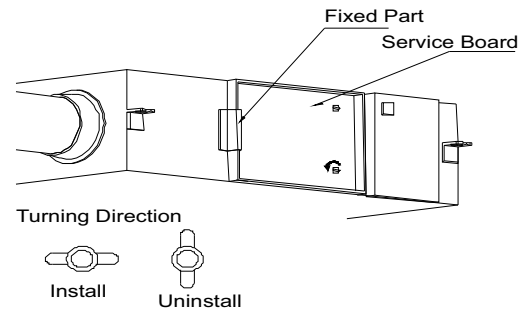

### Maintenance of heat exchanger

1. Pull off the filters first.
  2. Draw out the exchanger from the unit.
  3. Establish a cleaner schedule to clean the dust and dirt on the exchanger.
  4. Install the exchanger and filters to their positions and close the access door.
- Remarks: It is recommended maintenance of the exchanger is made every 3 years.

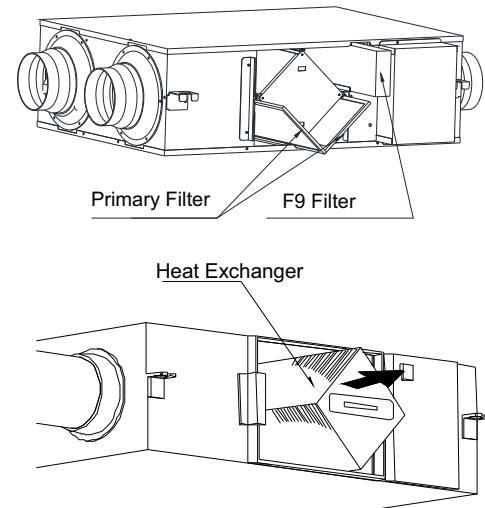

### Failure diagnose

User can use the unit after trial operation. Before contacting us, you can make self trouble shooting following below chart in case of any failure.

Phenomenon	Possible reason	Solutions
The airflow volumes both indoor and outdoor vents drop obviously after a period of operation.	Dust and dirt blocking the filter	Replace or clean the filter
Noise comes from vents	Vents installation are loosing.	Re-tightening the vents connections
Unit doesn't work	<ol style="list-style-type: none"> <li>1. No electricity</li> <li>2. Protection breaker is cut</li> </ol>	<ol style="list-style-type: none"> <li>1. Guarantee power is on</li> <li>2. Connect the breaker</li> </ol>

# GoLEED

Francisco Fernández Treviño #124 Col. Leones. CP 64600, Monterrey, N.L.

Teléfono 81 83-33-77-38 E-mail: info@airovac.com



@airovac