

# AF AG



## Manual Balancing Valves

2"-16" Steel venturi with butterfly Valve

# AF AG

The AccuSetter uses a low-loss venturi to obtain a measurement accuracy of 3% F. S. The butterfly has a 2" extended neck above the flange for insulation. The valve handle has an infinite-position memory stop for sizes 2" to 6" and a gear operator on 8" to 16" sizes. The total pressure drop added to the pump head seldom exceeds one foot. The exact drop can be calculated using the formula on Form F199. Flow measurement can be obtained with a differential pressure meter reading across the venturi taps. The GPM can be calculated using the formula on Form F199. (See "Flow Measurement Test Kits," form F011 for the differential pressure meter kits.) The design flow can be obtained by adjusting the valve operator until the desired GPM is reached. The set handle position is maintained by using the memory stop.



## Key features

- > **Low Loss Venturi**  
Measure with 3% accuracy
- > **Infinite Position**  
Fine adjustment
- > **Memory Stop**  
2" - 8"

## Technical description

**Application:**  
Hydronic Balancing

**Functions:**  
Balancing, measurement, shut-off

**Dimensions:**  
2" - 6", 8", 10", 12", 14", 16"

**Accuracy:**  
±3% F.S.

**Design:**  
Low loss piezo-ring throat

**Pressure class:**  
240 psig at 250° F (1655 kPa at 120° C)

**Material:**  
**Venturi Body:** Steel ASTM - A120  
**Instrument Valve:** Extended SuperSeal P/T Test Ports  
**Butterfly Valve Body:** Ductile Iron, full-lug type body, ANSI Class 125/150  
**Seat & Gasket:** EPDM  
**Stem:** Stainless Steel  
 Bearings: Nylon  
**Disc:** Stainless Steel *(if Al-Bronze is required please consult factory)*

## Model Information

### Model AF

Model AF AccuSetter includes a flanged venturi with a lug butterfly valve attached to the downstream side. Extended Pressure/Temperature Ports are standard.

- Field installation requires one 150# mating flange. Cap screws are included to mate the butterfly and the customer-supplied flange.

### Model AG

Model AG AccuSetter includes a grooved venturi on the entry with a lug butterfly valve mounted on the downstream exit end. The Model FG is also available as an option on all sizes. Extended Pressure/Temperature Ports are standard.

- Field installation requires one standard grooved coupling for the upstream attachment.

## Supplemental Installation Instructions

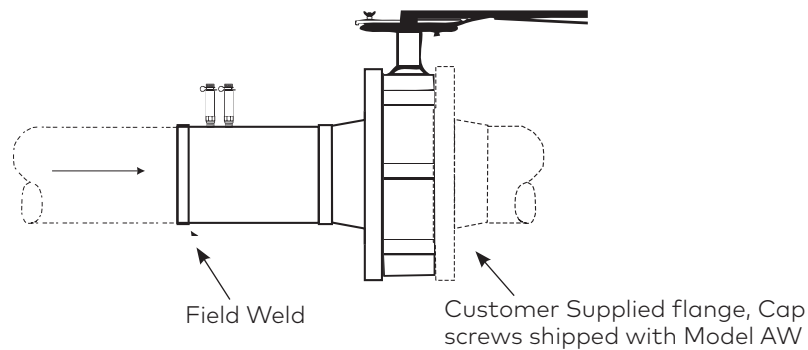

See Venturi & AccuSetter Valves Installation, Operation & Maintenance (F033) for more information.

## Articles

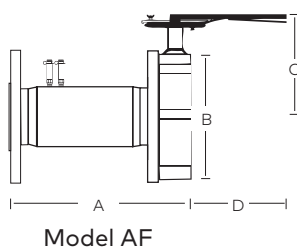

### Dimensions

Model	Size	Connections	A	B	C	D	Weight
AG0200(*)	2"	Grooved	9.4	6.0	6.6	10.0	19.3
AF0200(*)		150# Flange	8.4	6.0	6.6	10.0	20.6
AG0250(*)	2 1/2"	Grooved	9.4	7.0	7.2	10.0	25.2
AF0250(*)		150# Flange	8.4	7.0	7.2	10.0	27.6
AG0300(*)	3"	Grooved	10.5	7.5	7.6	10.0	34.0
AF0300(*)		150# Flange	11.00	7.5	7.6	10.0	35.0
AG0400(*)	4"	Grooved	13.45	9.0	8.4	10.0	53.0
AF0400(*)		150# Flange	13.95	9.0	8.4	10.0	53.7
AG0500(*)	5"	Grooved	13.95	10.0	9.0	10.0	61.3
AF0500(*)		150# Flange	14.45	10.0	9.0	10.0	64.7
AG0600(*)	6"	Grooved	14.65	11.0	9.7	10.0	78.6
AF0600(*)		150# Flange	15.15	11.0	9.7	10.0	86.6

## Articles

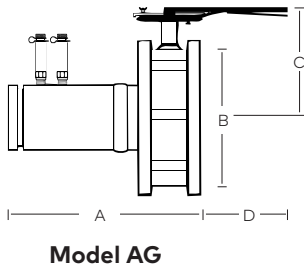

### Dimensions

Model	Size	Connections	A	B	C	D	Weight
AG0800(*)	8"	Grooved	15.5	13.5	7.5	8.0	123.3
AF0800(*)		150# Flange	16.00	13.5	7.5	8.0	135.7
AG1000(*)	10"	Grooved	16.80	16.0	7.5	9.0	178.3
AF1000(*)		150# Flange	17.30	16.0	7.5	9.0	194.5
AG1200(*)	12"	Grooved	18.95	19.0	7.5	9.0	279.6
AF1200(*)		150# Flange	19.45	19.0	7.5	9.0	307.0
AG1400(*)	14"	Grooved	20.90	21.0	11.8	9.0	399.3
AF1400(*)		150# Flange	21.40	21.0	11.8	9.0	372.9
AG1600L	16"	Grooved	21.50	16.0	11.8	9.0	550.9
AF1600L		150# Flange	22.50	23.5	11.8	9.0	539.9

### Notes

(\*) denotes L (low flow) or H (high flow) must be specified.

All weights and dimensions given are in pounds and inches and are subject to change.

Venturi products made from fabricated materials may vary  $\pm 1/16$  inch per component.

## Model Order Designation

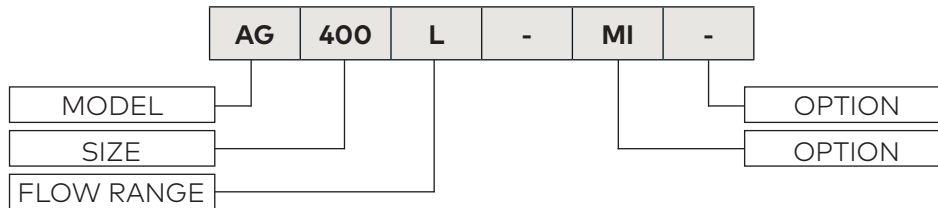

L = Low Flow H = High Flow

## Options Available

- |                               |                               |
|-------------------------------|-------------------------------|
| <b>AV</b> Manual Air Vent     | <b>CPT</b> Capillary Port/Tee |
| <b>C2</b> 1/2" Accessory Port | <b>HN</b> Hose End Drain      |
| <b>C3</b> 3/4" Accessory Port | <b>PI</b> Plastic ID Tag      |
| <b>C4</b> 1/4" Accessory Port | <b>MI</b> Metal ID Tag        |



The products, texts, photographs, graphics and diagrams in this document may be subject to alteration by IMI Hydronic Engineering without prior notice or reasons being given. For the most up to date information about our products and specifications, please visit [www.imiflowdesign.com](http://www.imiflowdesign.com).