

CW



Hook-up Components

2 1/2" - 8" Cast-Iron Flanged Strainer

Engineering
GREAT Solutions

CW

Cast-iron flanged strainers featuring a machined tapered seat which ensures a perfect fit for the removable, stainless steel screen. 1/4" ports (as shown) are available for additional options. All sizes come complete with flanged blow-off cover, gasket and plug. May be installed in vertical or horizontal pipe lines with blow-off connection at the lower end of the screen.



Key features

> **Machined Tapered Seat**
Removable stainless steel screen

> **1/4" Ports Available**
Additional option

Technical description

Application:
Hydronic Balancing

Pressure class:
125 psi at 250° F

Material:
Body: High Tensile ASTM A126 Class B
Cast Iron

Functions:
Strainer

Articles

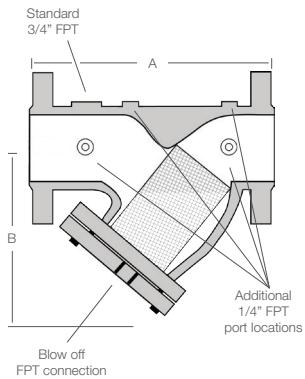

Dimensions

Nominal Dimensions (Inches) & Weights (Pounds) / Cv Rates

Model	Size	A	B	Blow Off		Screens	
				NPT	Weight	Mesh	Opening
CW0250	2 1/2"	10.9	7.6	1	42	0.045"	0.045"
CW0300	3"	11.7	8.3	1	49	0.045"	0.045"
CW0400	4"	13.8	10.1	1.25	86	1/8"	0.125"
CW0500	5"	15.7	12.5	1.25	121	1/8"	0.125"
CW0600	6"	18.8	13.0	1.5	143	1/8"	0.125"
CW0800	8"	21.8	13.9	1.5	267	1/8"	0.125"

Notes

All weights and dimensions given are in pounds and inches and are subject to minor changes. Port #1 standard 3/4" FPT, 1/4" ports available at additional cost.

Port Locations

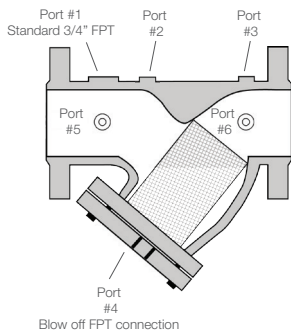

Model Order Designation

Model Size

2 1/2" CW Shown

Options

Use for options that require specified locations.
1 1/4" UB Shown

CW0250 - 1 1/4UB

Options Available

UB Ball Valve Port

PT Pressure Test Port

HN Hose End Drain Valve

XL Ext. P/T Port

HX Hose End Adaptor



The products, texts, photographs, graphics and diagrams in this document may be subject to alteration by IMI Hydronic Engineering without prior notice or reasons being given. For the most up to date information about our products and specifications, please visit www.flowdesign.com.