

G2..., G3... NPT Threaded Globe Control Valves

G2 Series NPT Threaded Globe Valves

Technical Data		
	G2...B	G2...S
Service	chilled or hot water, 60% glycol, steam	
Flow characteristic	modified equal percentage	
Action	stem up - open A to AB	
Sizes	½" to 2"	
End fitting	NPT	
Materials:		
Body	bronze	bronze
Stem	stainless steel	stainless steel
Plug	brass	stainless steel
Seat	bronze	stainless steel
Stem packing	EDPM o-ring	EDPM o-ring
Body pressure rating	ANSI Class 250	
Leakage	ANSI Class VI	
Max inlet pressure	35 psi [241 kPa]	100 psi [690 kPa]
Media temperature		
Water	20°F to 280°F [-7°C to +138°C]	20°F to 338°F [-7°C to +170°C]
Ambient temperature	32°F to 122°F [0°C to 50°C]	
Maximum ΔP		
Water	35 psi [241 kPa]	35 psi [241 kPa]
Steam	20 psi [138 kPa]	50 psi [345 kPa]
Rangeability	100:1	

G3 Series NPT Threaded Globe Valves

Technical Data	
	G3
Service	chilled or hot water, 60% glycol
Flow characteristic	modified equal percentage (linear flow B to AB)
Action	stem down - open A to AB stem up - open B to AB
Sizes	½" to 2"
End fitting	NPT
Materials:	
Body	bronze
Stem	stainless steel
Plug	brass
Seat	bronze
Stem packing	EDPM o-ring
Body pressure rating	ANSI Class 250
Leakage	ANSI Class VI
Media temperature	
Water	20°F to 280°F [-7°C to +138°C]
Ambient temperature	32°F to 122°F [0°C to 50°C]
Maximum ΔP	
Water	35 psi [241 kPa]
Rangeability	100:1

Flow Pattern

Two-way

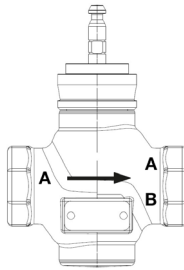

Three-way Mixing

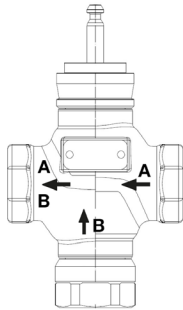

Three-way Diverting

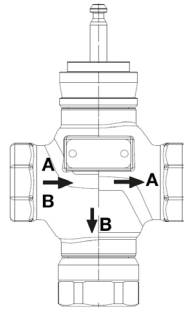

Operation

2-way Valve Piping Diagram
(1 Input, 1 Output)

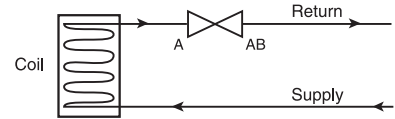

3-way Mixing Valve Piping Diagram
(2 Inputs, 1 Output)

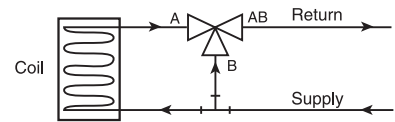

3-way Diverting Valve Piping Diagram
(1 Input, 2 Outputs)

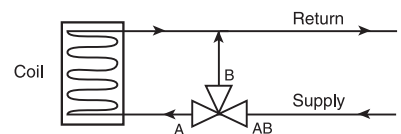

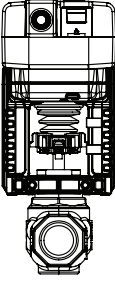
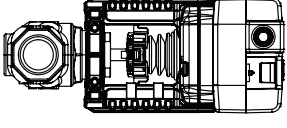
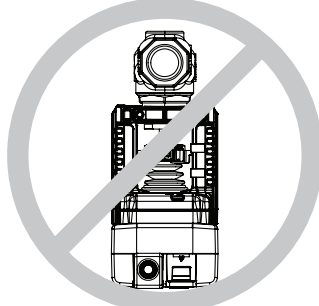
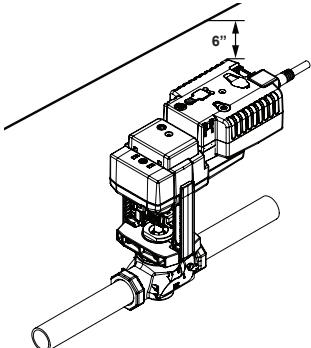
Mounting	
<p>Preferred Mounting</p> 	<p>Optional Mounting</p> 
<p>DO NOT INSTALL WITH ACTUATOR BELOW PIPE</p> 	
<p>Allow 6" for actuator/adaptor bracket removal. NOTE: DO NOT COVER ADAPTOR BRACKET WITH INSULATION MATERIAL.</p> 	

Installation

1. Inspect shipping package, valve, linkage, and actuator for physical damage. If shipping damage has occurred notify appropriate carrier. Do not install.
2. If a replacement, remove existing valve, linkage and actuator from the piping system.
3. If actuator and linkage are removed, they must be reinstalled correctly. The actuator must be rotated so that the valve sits properly for close off.
4. Install valve with the proper ports as inlets and outlets. Check that inlet and outlet of 2-way valves are correct; check that the "A", "B", and "AB" ports of 3-way valves are piped correctly for mixing or diverting. See supplied drawings on previous page.
5. Blow out all piping and thoroughly clean before valve installation.
6. Clean male pipe threads with wire brush and rag. If threads have been damaged or exposed to weather, running a tap or die over the threads may straighten them. Clean pipes, threads, and valve threads before installation; check for any foreign material that can become lodged in trim components. Strainers should be cleaned after initial startup.
7. Pipe sealing compound should be applied sparingly after cleaning and may not be applied to the two lead threads of a screwed pipe, which are innermost inside the valve. Sealing compound is to be placed on male threads only. The purpose is to lubricate the pipes when tightening.
8. Valve must be installed per the mounting drawings shown.
9. Start the connection by turning the valve or pipe by hand as far as possible. Be certain the threads mate by the "feel" of the connection.
10. Use wrenches to tighten the valve to the pipe. Do not over tighten or strip the threads. Two wrenches are necessary to avoid damaging the valve.
11. Two-way valve Normally Open or Closed configurations must be verified by examining both the mechanical drawings and the valve and actuator. See details below.
12. Three-way valve Normally Open or Closed configurations for the Control Port and the Bypass Port must be verified by examining both the mechanical drawings and the valve and actuator.

In the piping diagrams the A and B ports may need to be reversed or the actuator set up spring open or fail safe open differently than shown. The specific application determines what fail safe mode is required for freeze or moisture control if applicable.

Warning!

Valve should not be used for combustible gas applications. Gas leaks and explosions may result. Do not install in systems which exceed the ratings of the valve.

- Avoid installations where valve may be exposed to excessive moisture, corrosive fumes, vibration, high ambient temperatures, elements, or high traffic areas with potential for mechanical damage.
- Valve assembly location must be within ambient ratings of actuator.
- The valve assembly will require heat shielding, thermal isolation, or cooling if combined effect of medium and ambient temperatures – conduction, convection, and radiation – is above 122°F for prolonged time periods at the actuator.
- Strainers should be installed before coil and valve.
- Visual access must be provided. Assembly must be accessible for routine scheduled service. Contractor should provide unions for removal from line and isolation valves.
- Avoid excessive stresses. Mechanical support must be provided where reducers have been used and the piping system may have less structural integrity than full pipe sizes.
- Sufficient upstream and downstream piping runs must be provided to ensure proper valve capacity and flow response. Five diameters in each direction are recommended.
- Life span of valve stems and packing is dependent on maintaining non-damaging conditions. Poor water treatment or filtration, corrosion, scale, other particulate can result in damage to trim components. A water treatment specialist should be consulted.
- Normal thread engagement between male pipe thread and valve body should be observed. Pipe run that is in too far will damage the valve.

Safety Notes

WARNING: This product can expose you to lead which is known to the State of California to cause cancer and reproductive harm. For more information go to www.P65Warnings.ca.gov