

Top performance demands complete balance. **Macon**® balance.

Macon Balancing Valves deliver an efficient, dependable, and cost-effective solution to measuring

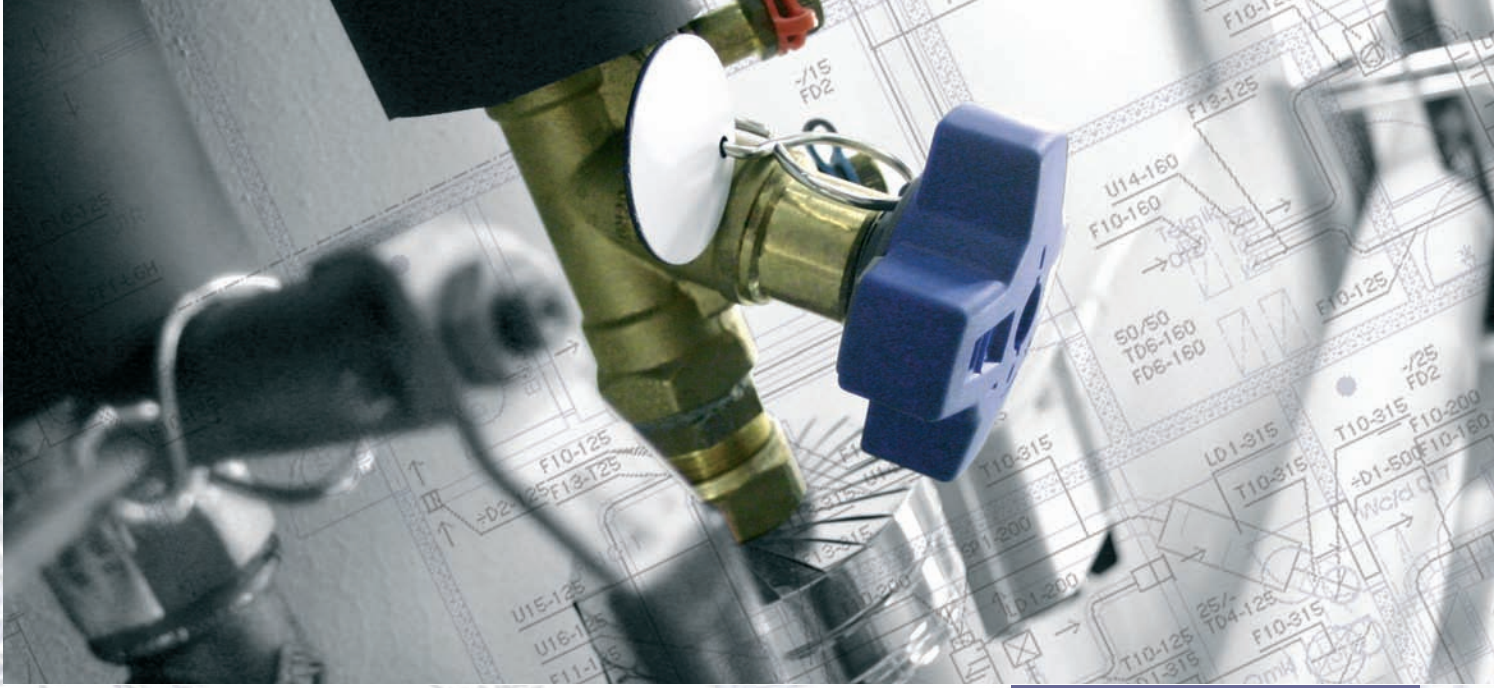

and balancing system flow rates that result in reduced maintenance, increased comfort and lower energy consumption.

MACON  **BALANCING MMA**

MACON BALANCING VALVES

Product Features

"Y" Pattern,
Globe style design

Accurate and precise
flow measurement

Accurate and precise
flow balancing

Positive shut-off

Offsetting Pressure/
Temperature ports, Self
sealing with optional
Drain Kits

Multi-turn, 360°
handwheel with vernier
scale and digital readout

Built in memory stop

Sweat, Thread, Flanged
and Groove connections

Wide variety of
accessories available

STVL SERIES

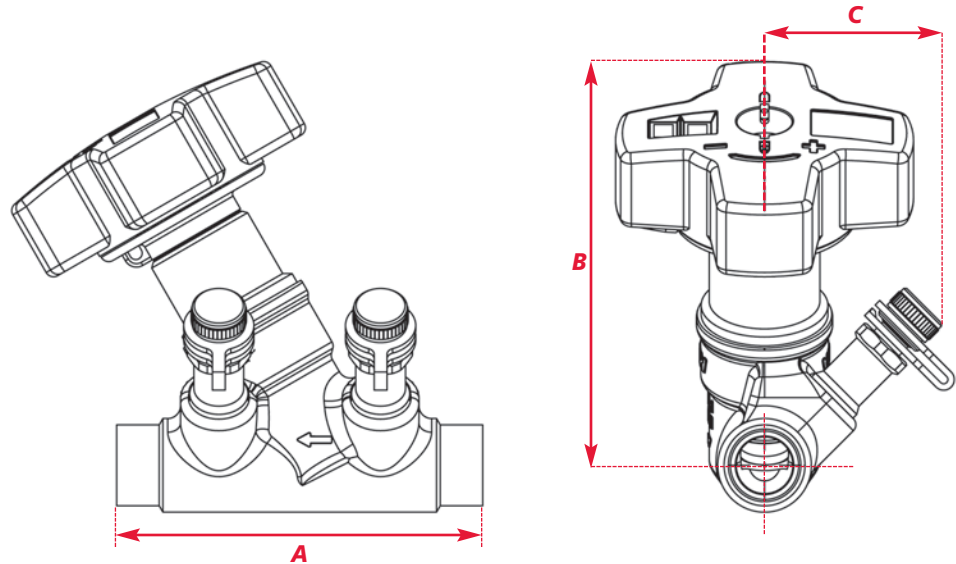

Specifications - STVL SERIES

Connection	Solder, Sweat	
Maximum Working Pressure	300 psi/20 Bar (PN 20)	
Operating Temperature Range	-22° F to 250° F (-30° C to 120° C)	
Materials of Construction	Body, Bonnet	Dezincification Resistant Brass
	Gaskets	EPDM
	Seat Seal	EPDM
	Handwheel	Polyamide Plastic

Valve Size		Dimensions			Approx. Weight	Handwheel Turns
Nominal Dimensions		Inches/mm				
Inches	mm	A - Length	B - Height	C - P/T Offset	lbs./kg	
1/2	DN 15	3.39 / 86	3.74 / 95	1.57 / 40	1.2 / 0.53	10
3/4	DN 20	3.54 / 90	3.74 / 95	1.65 / 42	1.3 / 0.58	10
1	DN 25	4.02 / 102	3.78 / 96	1.73 / 44	1.7 / 0.77	10
1 1/4	DN 32	4.72 / 120	3.78 / 96	1.85 / 47	2.7 / 1.2	10
1 1/2	DN 40	5.2 / 132	4.25 / 108	1.93 / 49	3.3 / 1.5	10
2	DN 50	6.46 / 164	4.37 / 111	2.09 / 53	5.1 / 2.3	10

STV SERIES

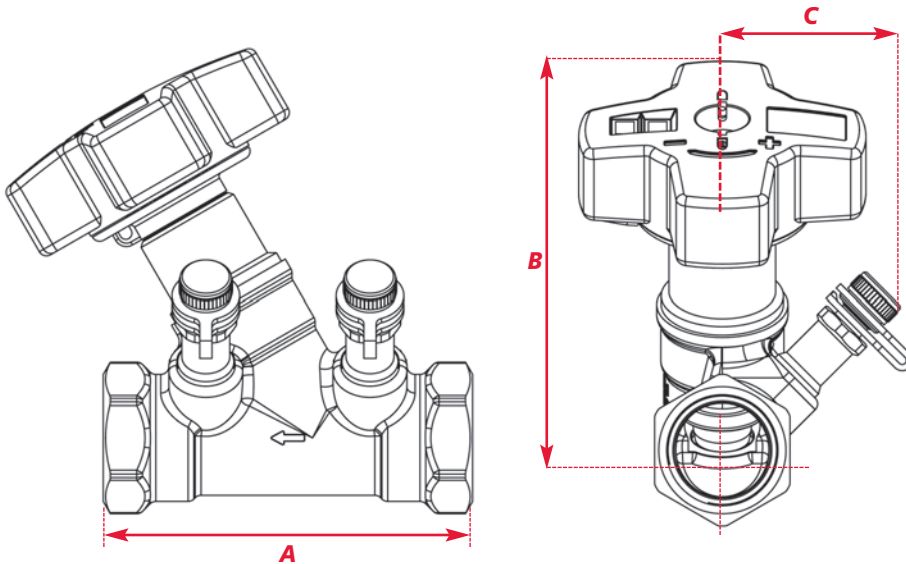

Get the most from your heating and cooling system with MACON Balancing Valves...always delivering optimal performance and maximum efficiency.

Specifications - STV SERIES

Connection	NPT (Fem.)	
Maximum Working Pressure	300 psi/20 Bar (PN 20)	
Operating Temperature Range	-22° F to 250° F (-30° C to 120° C)	
Materials of Construction	Body, Bonnet	Dezincification Resistant Brass
	Gaskets	EPDM
	Seat Seal	EPDM
	Handwheel	Polyamide Plastic

Valve Size		Dimensions			Approx. Weight	Handwheel Turns
Nominal Dimensions		Inches/mm				
Inches	mm	A - Length	B - Height	C - P/T Offset	lbs./kg	
1/2	DN 15	3.39 / 86	3.74 / 95	1.57 / 40	1.2 / 0.53	10
3/4	DN 20	3.54 / 90	3.74 / 95	1.65 / 42	1.3 / 0.58	10
1	DN 25	4.02 / 102	3.78 / 96	1.73 / 44	1.7 / 0.77	10
1 1/4	DN 32	4.72 / 120	3.78 / 96	1.85 / 47	2.7 / 1.2	10
1 1/2	DN 40	5.2 / 132	4.25 / 108	1.93 / 49	3.3 / 1.5	10
2	DN 50	6.06 / 154	4.37 / 111	2.09 / 53	5.1 / 2.3	10



STVA / STVC
Grooved ends also available. Consult factory for details.

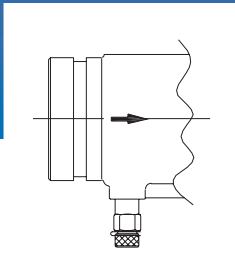

STVA / STVC SERIES

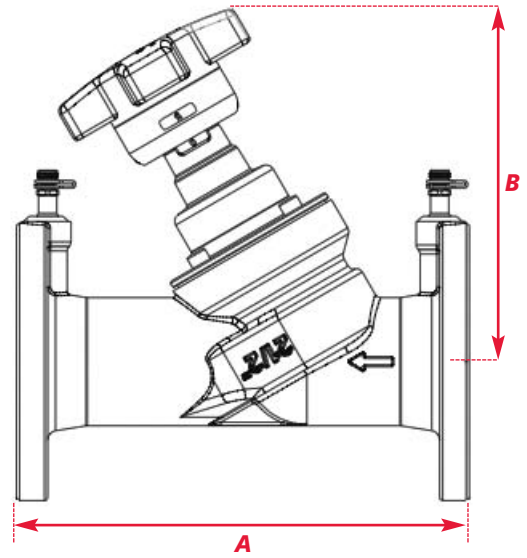

Specifications - STVA / STVC SERIES

Connection	ANSI 125# Flanged	
Maximum Working Pressure	250 psi/16 Bar (PN 16)	
Operating Temperature Range	-14° F to 250° F (-10° C to 120° C)	
Materials of Construction	Body, Bonnet	Cast Iron
	Gaskets	EPDM
	Seat Seal	PTFE
	Handwheel	Polyamide Plastic

STVA					
Valve Size		Dimensions		Approx.. Weight	Handwheel Turns
Nominal Dimensions		Inches/mm			
Inches	mm	A - Length	B - Height	lbs./kg	
2 1/2	DN 65	11.42 / 290	8.94 / 226	30.9 / 14	10
3	DN 80	12.2 / 310	9.5 / 241	44.1 / 20	10
4	DN 100	13.78 / 350	10.2 / 259	57.3 / 26	10
5	DN 125	15.75 / 400	11.73 / 298	88.2 / 40	10
6	DN 150	18.9 / 480	12.05 / 306	110.2 / 50	10

STVC					
Valve Size		Dimensions		Approx.. Weight	Handwheel Turns
Nominal Dimensions		Inches/mm			
Inches	mm	A - Length	B - Height	lbs./kg	
8	DN 200	23.6 / 600	20.1 / 510	275 / 125	12
10	DN 250	28.7 / 730	20.9 / 530	490 / 222	12
12	DN 300	33.5 / 850	24.0 / 610	573 / 260	18

Valve Selection Guide

Balancing Valves should be selected according to GPM flows, not line sizes.

Valve Size		Minimum Flow	Nominal Range of Flow	Maximum Flow
Nominal Dimensions				
Inches	mm	GPM/LPM	GPM/LPM	GPM/LPM
1/2	DN 15	0.14 / .52	0.5 - 3.8 / 1.89 - 14.36	12.1 / 45.7
3/4	DN 20	.26 / .98	3.8 - 5.5 / 14.36 - 20.8	17.4 / 65.7
1	DN 25	.37 / 1.38	5.5 - 9.5 / 20.8 - 36	30 / 113.4
1 1/4	DN 32	.60 / 2.28	9.5 - 14 / 36 - 53	44.6 / 169
1 1/2	DN 40	.91 / 3.46	14 - 20 / 53 - 76	66.4 / 251
2	DN 50	1.52 / 5.76	20 - 33 / 76 - 125	107.2 / 406
2 1/2	DN 65	2.13 / 8.07	33 - 100 / 125 - 378	318.3 / 1205
3	DN 80	4.19 / 15.9	100 - 117 / 378 - 442	374.5 / 1418
4	DN 100	6.09 / 23	117 - 200 / 442 - 756	646.8 / 2448
5	DN 125	7.61 / 28.8	200 - 320 / 756 - 1210	1025 / 3879
6	DN 150	13.7 / 51.9	320 - 440 / 1210 - 1663	1447 / 5477
8	DN 200	30.3 / 114	440 - 650 / 1663 - 2460	2100 / 7940
10	DN 250	76.3 / 289	650 - 1300 / 2460 - 4915	4050 / 15300
12	DN 300	76.3 / 289	1300 - 1600 / 4915 - 6050	4750 / 17590



The Minimum Flow is calculated from the minimum recommended pressure drop 1 ft. WG (=3.0 kPa)

The Nominal Flow is from the maximum setting of the valve and the minimum recommended pressure drop, 2 ft WG (=6.0 kPa)

The Max Flow is calculated from the maximum setting of the valve and the max pressure drop, 20 ft WG (=60.0 kPa)

The pressure drop tables on Pages 8, 9, & 10 can also be used for correct valve selection

Installation Recommendations

Install the valve in the correct flow direction according to the arrow on the valve body and the distance parameters detailed in Figure 1 (Note: D= pipe diameter).

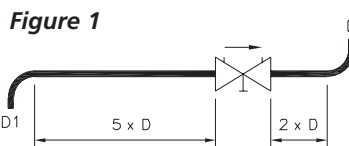

For Series STVL, cover the valve body with a wet cloth when soldering to prevent premature deterioration of valve components.

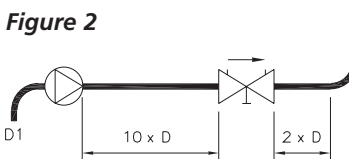

When used with a pump, it is recommended to use a straight length of pipe totaling 10 x D (instead of 5 x D) upstream or downstream to avoid turbulence that will affect the measuring accuracy. See Figure 2.

Turbulence can influence the measurements by up to 20% if this recommendation is not followed.

Figure 3

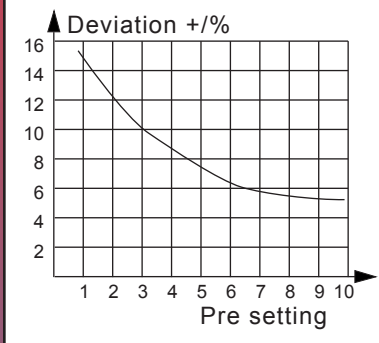

Flow Measurement & Accuracy

The measuring instrument connects to the test ports of the valve and is pre-programmed with Macon Balancing characteristics. The pressure drop and flow readings can be read off the display. If access to a Macon Balancing instrument is unavailable, other industry standard models are compatible. In addition, the flow can be determined using the pressure drop diagram that is included in the operating instructions with each Macon Balancing valve.

The accuracy is highest when the valve is fully open. Therefore, it is recommended to choose a valve that can be opened at least three turns at the calculated pre-setting value. Figure 3 represents the flow measurement deviation in relation to handwheel turns.

$$\text{Actual Flow} = \frac{q_{CBI}}{\sqrt{\quad}}$$

Correction For Liquids

Applies to liquids other than water. Correct the measured flow (q) by the density (γ) according to this formula.

$$C_v = 1.52 \frac{q}{\sqrt{\Delta p}}$$

q in GPM, Δp in Ft. of H2O

$$C_v = \frac{q}{\sqrt{\Delta p}}$$

q in GPM, Δp in PSI

Sizing a Balancing Valve

When the differential pressure and design flow are known, use this formula to calculate Cv value. The Macon Balancing pressure drop tables on pages 8 to 10 can also be used.

Typical Specification

All balancing valves shall be of one manufacturer.

Furnish and install, as shown on job plans and in accordance with manufacturers installation instructions, Macon Balancing Valves, Series STVL/STV/STVA/STVC. Valves are to be of "Y" pattern globe style design and perform the following functions: a) Flow balancing, b) Flow measurement, c) Positive shut-off.

All balancing valves must have a minimum ten (10) turn, 360° handwheel with digital and vernier scale readout for precise setting. Balancing handwheel must include a memory stop and locking feature to prevent tampering after pre-setting.

All balancing valves shall have self-sealing ports for measurement of differential pressure and fluid temperature using standard pressure and temperature test probes. Test ports shall be located at a 45° offsetting angle and be removable for implementation of optional drain kits where required.

All balancing valves in sizes 1/2" (DN 15) through 2" (DN 50) shall be made of dezincification resistant brass and have either sweat or NPT thread connections. Valve body sizes 2 1/2" (DN 65) through 12" (DN 300) shall be made of cast iron and flanged to 125lb standard.

All balancing valves shall be manufactured by the company complying with international quality standard ISO 9001.

C_v Values for Valve Series STVL, STV, STVA

Flow coefficient values (Cv's) at various handwheel settings											
Handwheel Setting	1/2" DN 15	3/4" DN 20	1" DN 25	1 1/4" DN 32	1 1/2" DN 40	2" DN 50	2 1/2" DN 65	3" DN 80	4" DN 100	5" DN 125	6" DN 150
1	0.21	0.39	0.56	0.92	1.39	2.32	3.2	6.4	9.3	11.6	20.9
1.5	0.29	0.56	0.75	1.28	1.97	3.25	4.6	8.7	12.8	19.7	29
2	0.37	0.7	0.89	1.53	2.38	4.18	5.9	11	15.7	25.5	38.3
2.5	0.44	0.82	1.04	1.8	2.78	5.1	8.5	13.3	19.1	30.2	53.4
3	0.52	0.96	1.19	2.09	3.25	6.03	11.1	15.7	22	38.3	78.9
3.2	0.56	1.02	1.28	2.26	3.48	6.5	13.1	16.6	23.8	42.9	90.5
3.4	0.59	1.09	1.39	2.44	3.71	6.96	15.1	17.5	25.5	48.7	103
3.6	0.63	1.16	1.51	2.67	4.06	7.54	17.4	18.6	29	55.7	118
3.8	0.67	1.23	1.62	2.9	4.41	8.12	20.3	19.7	33.6	63.8	135
4	0.72	1.31	1.74	3.13	4.76	8.82	23.2	21.5	38.3	73.1	151
4.2	0.77	1.39	1.91	3.42	5.1	9.74	26.8	23.2	45.2	82.4	164
4.4	0.81	1.48	2.09	3.71	5.57	10.7	30.4	24.9	53.4	91.6	176
4.6	0.87	1.58	2.26	4.06	6.03	11.7	34	27.3	61.5	102	189
4.8	0.93	1.68	2.44	4.41	6.61	12.8	37.6	30.7	69.6	113	202
5	1	1.8	2.67	4.76	7.19	13.8	41.2	34.2	77.7	123	216
5.2	1.07	1.91	2.9	5.16	7.77	15	44.8	38.3	85.8	135	231
5.4	1.14	2.03	3.19	5.57	8.35	16	48.4	42.9	94	146	246
5.6	1.21	2.16	3.48	5.97	8.93	17.2	52	47.6	102	157	260
5.8	1.28	2.3	3.83	6.38	9.63	18.3	55.6	52.2	109	166	273
6	1.36	2.44	4.18	6.84	10.3	19.4	59.2	56.8	115	174	285
6.2	1.44	2.6	4.47	7.25	11	20.4	62.6	61.5	122	183	298
6.4	1.52	2.76	4.76	7.66	11.8	21.5	66.1	66.1	129	194	311
6.6	1.62	2.96	5.1	8.12	12.5	22.5	69.6	70.8	135	204	322
6.8	1.74	3.16	5.45	8.58	13.2	23.5	73.1	75.4	140	215	332
7	1.88	3.36	5.8	9.05	13.9	24.6	76.6	79.5	145	225	341
7.2	2.06	3.6	6.15	9.51	14.6	25.5	80	83.5	151	235	351
7.4	2.26	3.83	6.5	9.98	15.3	26.4	82.9	87.6	157	246	363
7.6	2.49	4.06	6.84	10.4	15.9	27.4	85.8	91.6	162	255	374
7.8	2.73	4.27	7.19	10.8	16.5	28.2	88.7	95.1	168	264	384
8	2.96	4.47	7.54	11.3	17.1	29	91.1	98.6	174	274	394
8.2	3.13	4.63	7.89	11.7	17.6	29.9	93.4	102	180	283	406
8.4	3.29	4.78	8.24	12.2	18.2	30.7	95.7	105	186	292	418
8.6	3.42	4.93	8.58	12.6	18.8	31.6	97.4	108	190	302	428
8.8	3.54	5.08	8.87	13	19.4	32.4	99.2	111	194	310	437
9	3.65	5.22	9.16	13.3	19.8	33.2	101	114	197	317	447
9.2	3.77	5.36	9.4	13.7	20.3	33.9	103	116	202	324	456
9.4	3.87	5.5	9.63	14.2	20.9	34.6	104	119	206	331	465
9.6	3.98	5.64	9.86	14.5	21.5	35.3	106	123	211	338	474
9.8	4.06	5.78	10	14.8	22	36	107	125	216	343	484
10	4.12*	5.92*	10.2*	15.2*	22.6*	36.5*	108*	128*	220*	349*	493*

* Valve is fully open

C_v Values for Valve Series STVC

Use the corresponding diagram to calculate and size a piping system. The pressure drop diagram on page 10 can also be used.

Flow coefficient values (Cv's) at various handwheel settings			
Handwheel Setting	8" DN 200	10" DN 250	12" DN 300
2	46	116	116
3	66	160	180
4	84	204	244
5	139	349	396
6	215	494	546
7	290	689	708
8	365	884	869
9	452	1031	1012
10	545	1177	1153
11	638	1291	1290
12	696*	1405*	1427
14	-	-	1588
16	-	-	1668
18	-	-	1764*

* Valve is fully open



Use this diagram to calculate and size a piping system.

The pressure drop diagram on pages 8 and 9 can also be used.

PRESSURE DROP TABLES

Series STVL & STV, 1/2" – 2"

This diagram details the relationship between flow, pressure drop and valve pre-set points. Use the diagram to select the correct valve size and corresponding handwheel setting to fulfill the application requirements.

Determine the required flow in the circuit (A) and the pressure drop (B). Draw a line between these two values. Read off the corresponding Cv value on the Cv scale (C).

Determine the valve setting, in handwheel turns, by drawing a horizontal line (D) from the intersection point on the Cv scale to the corresponding valve setting position.

For the highest level of accuracy, it is recommended to choose a valve that has at least 3 open turns.

Example: A 1" valve is required to be open 8 turns for a Cv value of 7.5 at a flow rate of 10 gpm and a pressure drop of 4 ft.

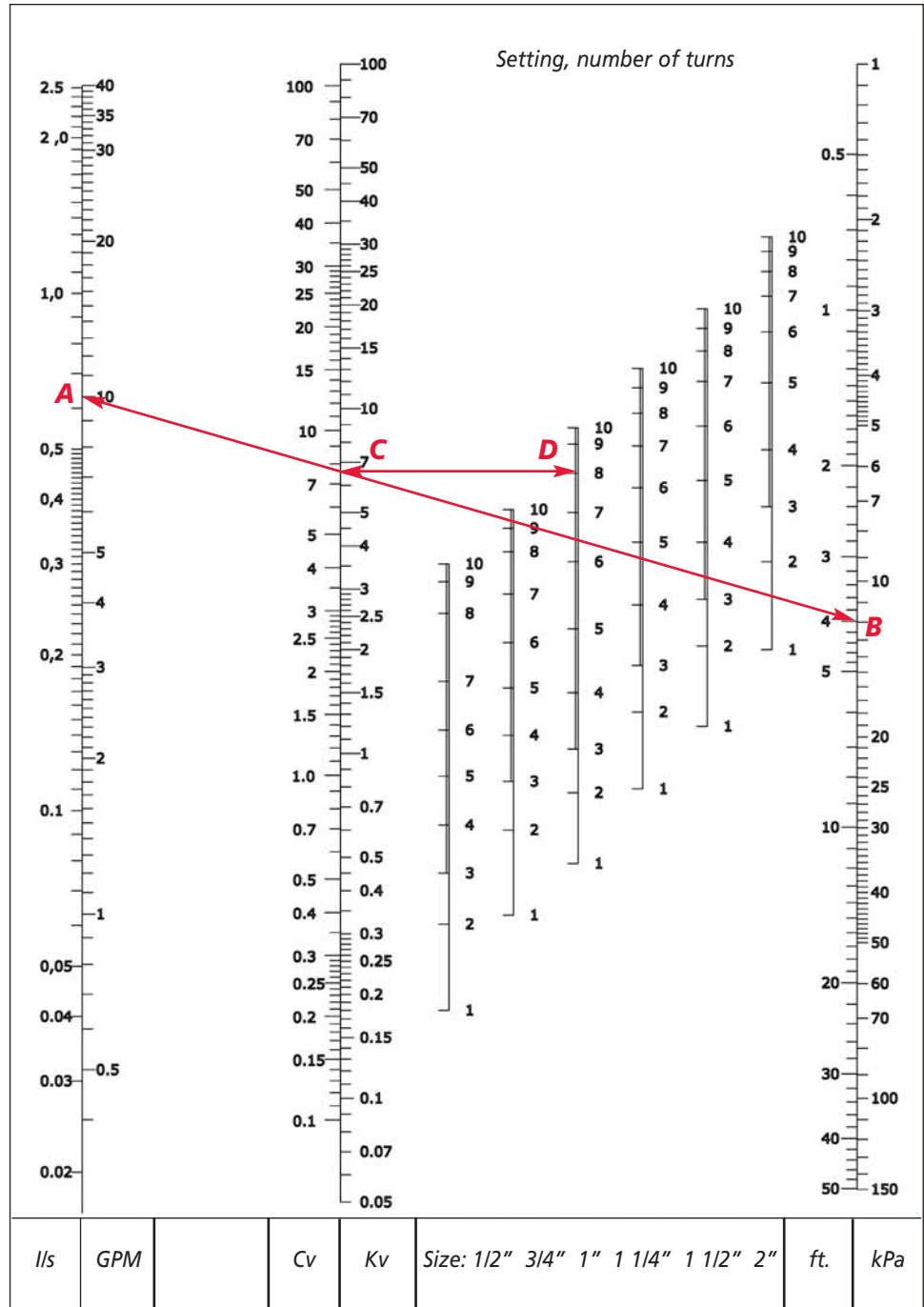

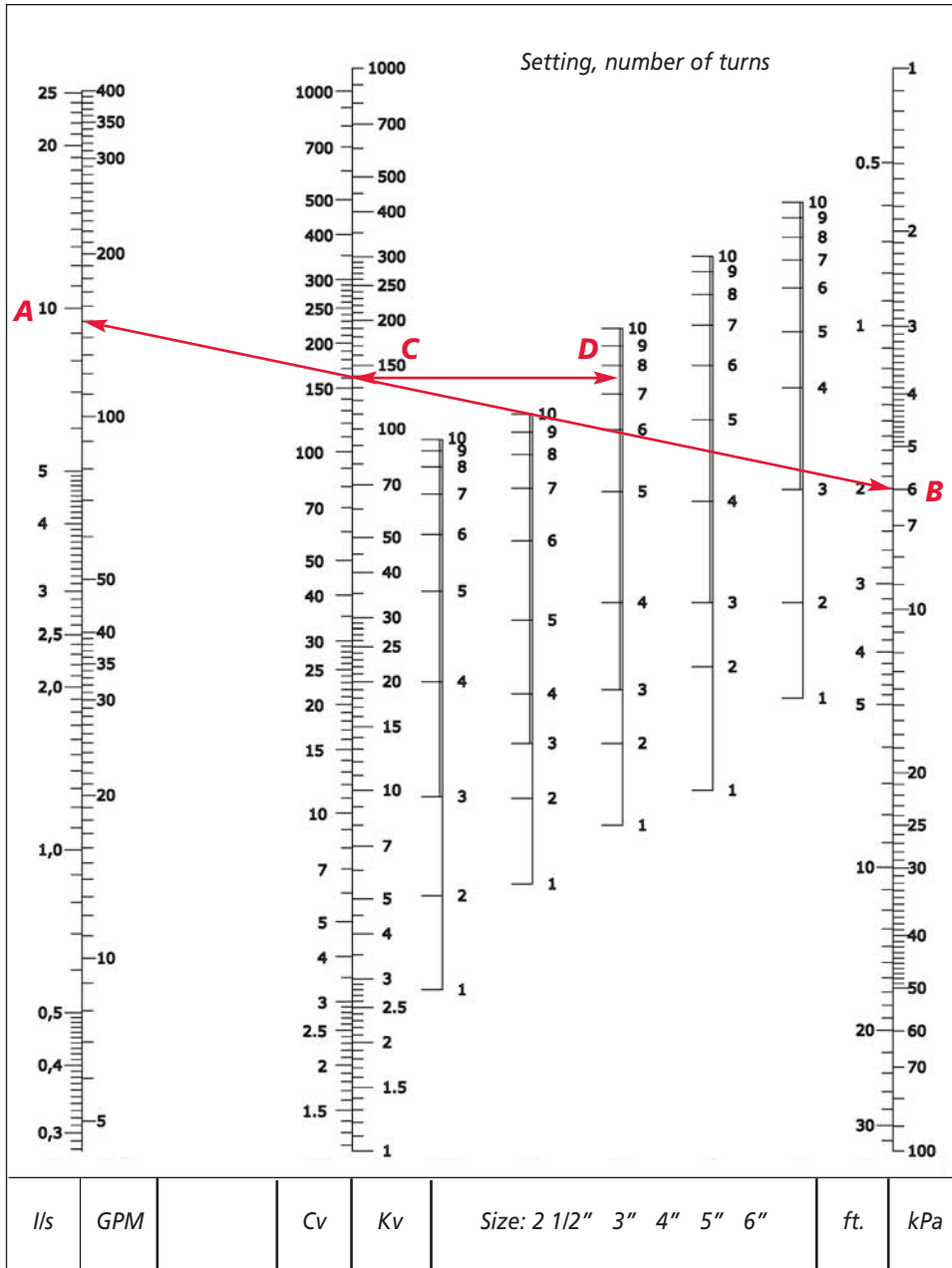

Series STVA, 2 1/2" – 6"

This diagram details the relationship between flow, pressure drop and valve pre-set points. Use the diagram to select the correct valve size and corresponding handwheel setting to fulfill the application requirements.

Determine the required flow in the circuit (A) and the pressure drop (B). Draw a line between these two values. Read off the corresponding Cv value on the Cv scale (C).

Determine the valve setting, in handwheel turns, by drawing a horizontal line (D) from the intersection point on the Cv scale to the corresponding valve setting position.

For the highest level of accuracy, it is recommended to choose a valve that has at least 3 open turns.

Example: A 4" valve is required to be open 7.5 turns for a Cv value of 160 at a flow rate of 150 gpm and a pressure drop of 2 ft.

**Series STVC,
8" – 12"**

This diagram details the relationship between flow, pressure drop and valve pre-set points. Use the diagram to select the correct valve size and corresponding handwheel setting to fulfill the application requirements.

Determine the required flow in the circuit (A) and the pressure drop (B). Draw a line between these two values. Read off the corresponding Cv value on the Cv scale (C).

Determine the valve setting, in handwheel turns, by drawing a horizontal line (D) from the intersection point on the Cv scale to the corresponding valve setting position.

For the highest level of accuracy, it is recommended to choose a valve that has at least 3 open turns.

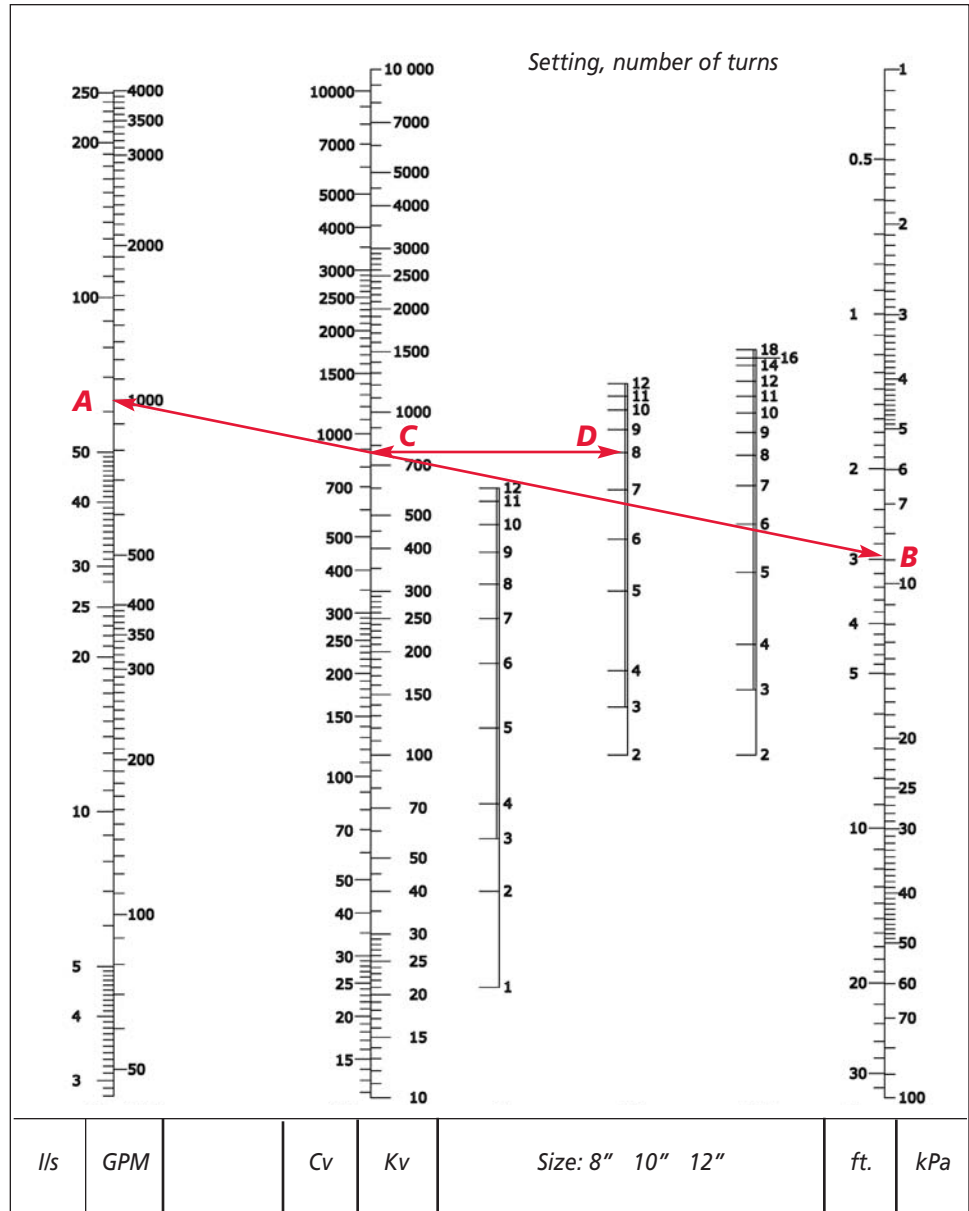

Example: A 10" valve is required to be open 8 turns for a Cv value of 890 at a flow rate of 1000 gpm and a pressure drop of 3 ft.

MACON ACCESSORIES

A wide variety of Macon Balancing accessories are available.



Drains

- Max working pressure of 150psi/10 bar
- Must be installed before filling system
- Original O-rings make other sealing methods unnecessary



Ports

- Self sealing
- Accepts and compatible with industry standard insertion probes

Port Extensions

- Allows for access where pipe insulation is used



Insulation

- For heating and cooling



Measuring stations

- Threaded and Flanged connections available
- Self sealing test ports

Balancing instrument

- Contains flow characteristics of all Macon Balancing valves
- Ability to save data for PC printout
- Ability to measure system pressure head



Handwheels

- Multi-turn, 360° handwheel
- Vernier scale & digital readout





MACON BALANCING

A Division of Tunstall Corporation

118 Exchange Street

Chicopee, MA 01013

Phone: 413-594-8695

Toll Free: 800-423-5578

Fax: 413-598-8109

www.maconbalancing.com

*Information contained in this brochure
may be altered without notice.*

