

**IMPORTANT! Read and save these instructions. This manual to be left with the equipment.**



**DR**  
SERIES



# INSTALLATION, OPERATION AND MAINTENANCE MANUAL

## Nortec AF-22

# Thank you for choosing Nortec

Installation date (DD/MM/YYYY):

Commissioning date (DD/MM/YYYY):

Site:

Model:

Serial number:

Nortec Humidity Ltd.  
2740 Fenton Road, Ottawa, ON, Canada K1T 3T7  
Tel. 1.866.NORTEC1, Fax 613.822.7964  
nortec@humidity.com, www.humidity.com.

## **Proprietary Notice**

This document and the information disclosed herein are proprietary data of Nortec Humidity Ltd. Neither this document, nor the information contained herein shall be reproduced, used, or disclosed to others without the written authorization of Nortec Humidity Ltd., except to the extent required for installation, operation or maintenance of the customer's equipment.

## **Liability Notice**

Nortec Humidity Ltd. does not accept any liability due to incorrect installation, maintenance or operation of the equipment, or due to the use of parts/components/equipment that are not authorized by Nortec Humidity Ltd.

## **Copyright Notice**

Copyright 2016, Nortec Humidity Ltd, All rights reserved.

Technical modification rights reserved.

# Contents

---

<b>1</b>	<b>Introduction</b>	<b>1</b>
1.1	Before You Start!	1
1.2	General	1
<b>2</b>	<b>For Your Safety</b>	<b>3</b>
<b>3</b>	<b>Product Overview</b>	<b>5</b>
3.1	AF-22	5
3.2	AF-22 Functional description	6
<b>4</b>	<b>Basic Principles for Planning</b>	<b>7</b>
4.1	Notes on the planning of air humidification systems in one area	7
4.2	Notes on the planning of an air humidification system in multiple areas	7
4.3	Notes on the water supply	7
4.3.1	Requirements regarding untreated water (drinking water or raw water)	8
4.4	Notes on compressed air supply	9
4.5	Notes on the run of the tubes	9
<b>5</b>	<b>Installation</b>	<b>10</b>
5.1	Safety notes on installation	10
5.2	General notes on positioning	10
5.3	General notes on assembly	10
5.3.1	Standard Mounting	11
5.4	Electrical installation	13
5.4.1	AF-22	13
5.5	Material specifications	15
5.5.1	Protective tube	15
5.5.2	Air tube and water tube	15
5.5.3	Cables	15
<b>6</b>	<b>Operation</b>	<b>16</b>
6.1	Switching off during daily operation	16
6.1.1	Switching off completely	16
6.1.2	Partial switching-off	16
6.2	Setting to operation on a daily basis	17
6.3	Routine checks	17
6.3.1	Atomizer AF-22	17
<b>7</b>	<b>Replacement of Components</b>	<b>18</b>
<b>8</b>	<b>Technical Data</b>	<b>20</b>
<b>9</b>	<b>Appendix</b>	<b>21</b>
9.1	Spare Parts / Options	21
9.2	AF-22 Humidification Load Calculation Examples	21
9.2.1	Example 1 (AF-22)	21
9.2.1.1	Calculating the maximum humidification capacity	22
9.2.1.2	Determining the device requirements	22
9.2.1.3	Determining the compressed air and water requirements	23
9.2.2	Example 2 (AF-22 in multiple areas)	24
9.2.2.1	Calculating the maximum humidification capacity	24
9.2.2.2	Determining the device requirements	25
9.2.2.3	Determining the compressed air and water requirements	26
9.3	Psychometric Chart (Imperial)	27
9.4	Psychometric Chart (Metric)	28

This page intentionally left blank.

# 1 Introduction

## 1.1 Before You Start!

Thank you for purchasing the Nortec AF-22 humidifier.

The Nortec AF-22 humidifier incorporates the latest technical advances and meets all recognized safety standards. Nevertheless, improper use of the Nortec AF-22 humidifier may result in danger to the user or third parties, and/or damage to property.

To ensure safe, proper and economical operation of the Nortec AF-22 humidifier, observe and comply with all information and safety instructions contained in this manual, as well as all relevant documentation of components of the installed humidification system. Comply with all local and regional regulations dealing with gas, combustion air, flue gases, water, steam and electrical installations.

If you have additional questions, contact your Nortec representative. They will be glad to assist you.

## 1.2 General

### Limitations

The subject of this manual is the Nortec AF-22 humidifier. The various options and accessories may only be described in-so-far as is necessary for proper installation and operation of the equipment. Additional information on available options and accessories can be obtained in the instructions that are supplied with them.

This manual is restricted to the installation of the Nortec AF-22 humidifier, and is intended for well trained personnel who are suitably qualified for their respective tasks.

### Symbols Used in This Manual



**CAUTION!**

The catchword "CAUTION" in conjunction with the general caution symbol is used to provide safety instructions that, if neglected, may cause damage and/or malfunction of the unit or damage to property.



**WARNING!**

The catchword "WARNING" in conjunction with the general warning symbol is used to provide safety instructions that, if neglected, may cause injury to personnel. Other specific warning symbols may also be used in place of the general symbol.



**DANGER!**

The catchword "DANGER" in conjunction with the general danger symbol is used to provide safety instructions that, if neglected, may cause severe injury to personnel or even death. Other specific danger symbols may also be used in place of the general symbol.

## **Storage of Manual**

Keep this manual in a place where it is safe and readily accessible. If the equipment is moved to another location, make sure that the manual is passed on to the new user.  
If the manual is lost or misplaced, contact your Nortec representative for a replacement copy.

## 2 For Your Safety

### Agreement on use



#### WARNING!

The air humidification system is exclusively designed for the controlled humidifying of rooms within the framework of the specified operating conditions in rooms that are not explosion-endangered. Any other utilisation is regarded as not contractual and may result in risks caused by the system.

Contractual use also implies serving of all pieces of information contained in this instruction manual (especially the notes on safety) and strictly paying attention to the operation conditions.

### General notes on safety

Only persons who made themselves familiar with the product and who are sufficiently qualified for the relevant works may install and operate it. Amending the different technical documentation sheets by means of company-internal directions concerning the responsibility and the obligatory registration, work organization, qualification of the personnel, etc. lies within the customer's responsibility.

In accordance with chapter 6, the system has to be switched off before starting works on components of the air humidification system and is to be secured against unintended putting into operation (switch off the control device, shut off the water supply and ensure the system is depressurized).



#### CAUTION!

Pay attention to all local **safety regulations**:

- Concerning **electric and electronic devices** that are supplied from the mains.
- Concerning **installation of water systems**.

Badly maintained air humidification systems may be harmful to health. Therefore it is obligatory to comply with the intervals of maintenance.

If it is to be assumed that the air humidification system cannot be operated without danger anymore, it has to be switched off immediately and to be secured against unintended activation. This can be the case under the following circumstances:

- Components of the system are damaged
- The system does not work correctly anymore
- Connections or pipes are leaking

The air humidification system is to be operated only within the framework of the specified operating conditions.



#### WARNING!

The control devices of the air humidification system are only to be operated with 48 VAC safety extra-low voltages.

Make sure the control devices are secured against drip-water at the place of assembly.



**CAUTION!**

When the air humidification system is installed in a room without water drainage, water level sensors that safely close the water supply (in case of a possible leakage in the water-supply system) have to be installed in the room.

---

In order to avoid water damage, do not store any **materials that can be damaged by water directly under the atomizer nozzle.**



**DANGER!**

**Danger of corrosion!** To avoid dangers, do not store any corrosive components within the area of the aerosol flow (no rebounding surface for the aerosols).



**CAUTION!**

Depending on the content of minerals in the pipe water or the treated water respectively, scale deposits that are more or less pronounced can form. Sensitive materials and devices have to be protected appropriately or to be moved out of this area.

---

Apart from the works described in this manual, no further interventions have to be carried out on the air humidification system.

Use only the original accessories and spare parts from Nortec.

Without the written consent of Nortec, no changes may be carried out on the air humidification system.

In case of changes on the system, an approval carried out by Nortec customer service or by persons authorized by Nortec has to be carried out prior to the first switching on.



# 3 Product Overview

## 3.1 AF-22

### System description

The system mainly consists of atomization of water supplied into the air. All system components are integrated into a plastic housing. The atomizing nozzles are assembled firmly onto the upper part of the housing. In addition, every device is fitted with a hygostat which measures the relative humidity (indicated in percent RH - %) in the ambient air. It compares the measured value with the pre-selected set point and thus controls the device.

Individual smaller rooms or large halls can be humidified, depending on the quantity of water that is available and the length of the hoses. The atomizers are designed for wall mounting and are delivered ready for connection.

Table 1: Technical Specification Overview

Designation	Number of nozzles	Max. humidifying capacity at an atomizing pressure of 5 bar)
AF-22	2	22 lbs/hr (10 L/h)

The AF-22 is a two-component atomizer. That means that it needs both water and compressed air for atomizing.

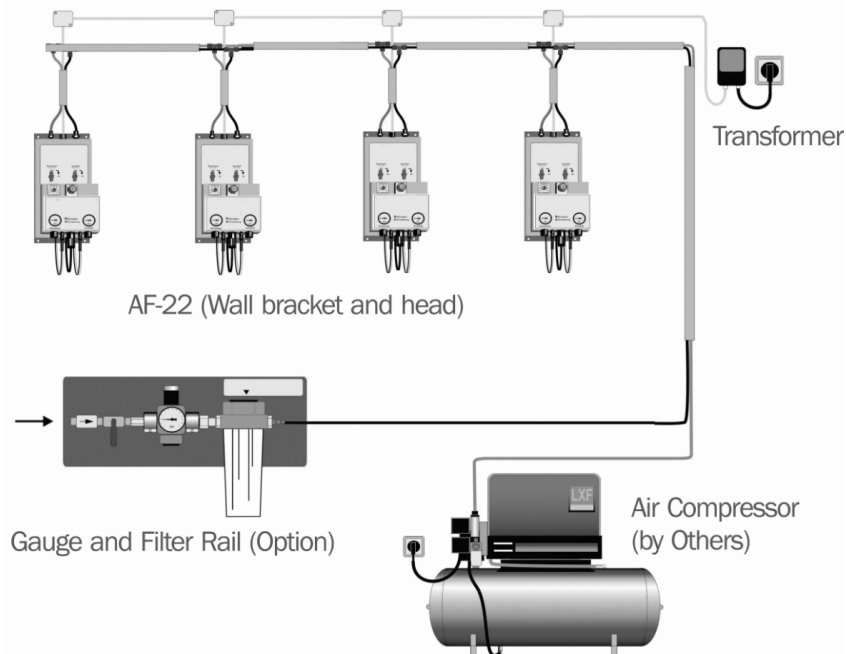

Figure 1: Typical setup of the system (illustration shows the AF-22)

## 3.2 AF-22 Functional description

The AF-22 is controlled by a hygrostat that is placed in the atomizer head.

The device consists of two components: the wall bracket (1) and the atomizer (2).

The wall bracket consists of the shut-off valves for water (3) and air (4) as well as the supply lines for water (5), air (6) and operating voltage (7).

The atomizer consists of the set point adjuster (9), the nozzle (8) as well as the LED indicator lights standby (green) and atomization (red) (10).

The desired air humidity is pre-selected on the set point adjuster. When the value falls short of the chosen value, the device switches itself on (LED atomization emits light). When the set point is reached again, the device switches itself off.

The compressed air supply remains switched on, also after the water was switched off, for about 1 minute (air-blowing).

The standby indicator lights up as soon as the operating voltage (48 VAC) is available on the device.

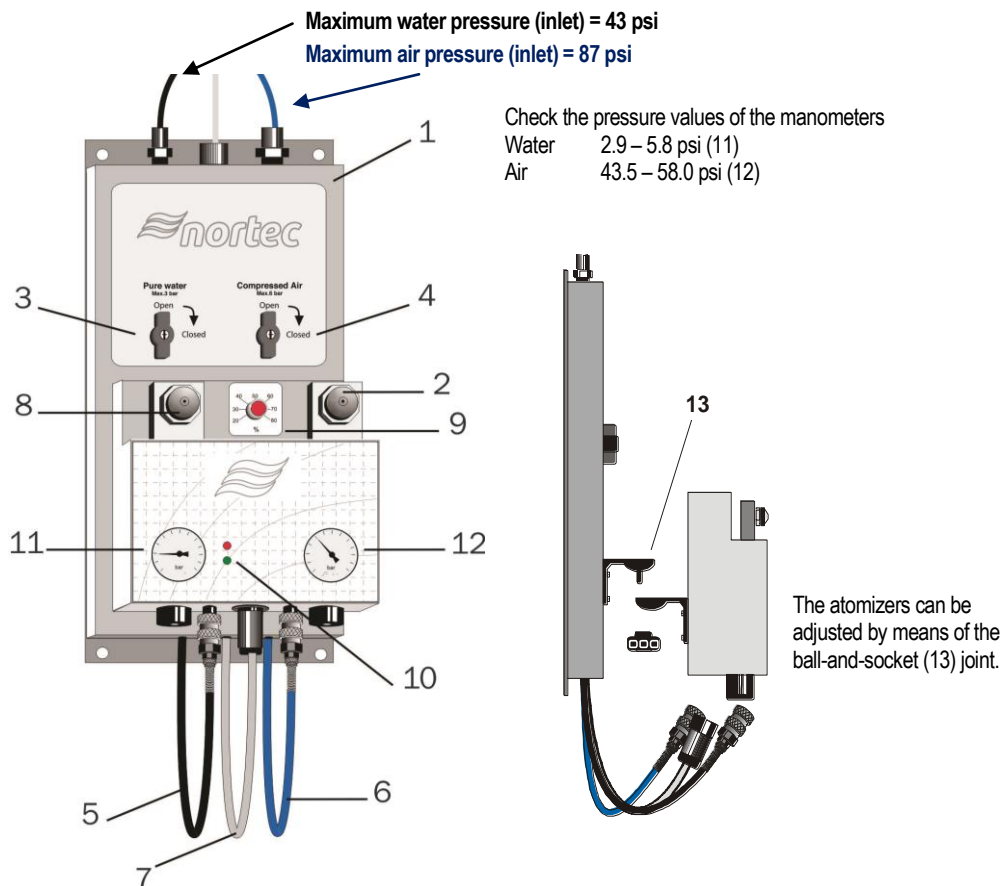

Figure 2: AF-22 bracket and atomizing system components

## 4 Basic Principles for Planning

The basic principles for planning described below are theoretical ones. In practice, the necessary humidification capacity is influenced by parameters that cannot be covered by this documentation. For this reason, the values that were determined in theory have to be complemented by practical values or corrected in many cases. Our technical service team will be pleased to assist you.

### 4.1 Notes on the planning of air humidification systems in one area

Proceed as follows when selecting and/or dimensioning the air humidification system:

- Determining the volume of the room and the air changes
- Determining the set points (temperature and humidity/relative humidity)
- Determining the humidification areas
- Calculating the maximum humidification capacity
- Defining the device requirements

Chapter 9 (Appendix) contains all necessary pieces of information on the individual planning steps. For every planning step, a **calculation example** based on assumed system data has been included. The three different examples are supposed to illustrate the procedure. Naturally it is not possible to cover all applications by means of examples. The air humidification system offers a variety of solutions for individual air humidification in a large variety of rooms.

Nortec distribution and customer service team will be pleased to assist you in case you have any questions. **Telephone: + 1 (262) 884-4669**

### 4.2 Notes on the planning of an air humidification system in multiple areas

In Section 9.2.2 you can see a large room that is, however, divided up into two areas of humidification. When a room has areas with different heat loads or when the number of air changes is not identical for the entire room, the atomizers are not able to deliver sufficient measuring results. Certain areas would not be humidified sufficiently and others would be humidified too much. In these cases and similar cases, the room can be divided up into two areas of humidification.

### 4.3 Notes on the water supply

The Nortec AF-22 is a hygienic system and therefore makes particular demands as far as the water to be atomized is concerned.

The systems can also be operated using untreated source water, but this involves different risks:

- Depending on the quality of the untreated water, operating safety may be impaired
- Depending on the quality of the untreated water, hygiene may be impaired (depends on the organic contamination of the untreated water)
- Depending on the quality of the untreated water, a very pronounced mineral precipitation may occur. These substances contained in untreated water precipitate out of the small droplets (aerosols) and settle on all surfaces. The functioning of processes and machines may be impaired and more cleaning needs to be done

#### **NOTE:**

We recommend you to always use a Nortec water treatment unit in order to achieve optimal results as far as hygiene and operating safety are concerned.

All requirements regarding water treatment listed below are extremely important in order to ensure a safe, hygienic operation. The operator shall ensure that the following requirements are met on a permanent

basis. They are fulfilled when a Nortec clean water system is used. The AF-22 also has to be subjected to regular inspection and preventative maintenance on a regular basis.

Definition of terms:

- **Untreated water:** This kind of water is water to be subjected to water treatment. Also known as potable water
- **Soft water:** See also 4.3.2. This is water that has been softened
- **Treated water:** This kind of water is a product of water treatment. Another term for treated water is reverse osmosis treated water (RO water)



#### **WARNING!**

Despite compliance with these requirements, contamination of the system cannot be excluded. Regular checks carried out by the operator are obligatory in order to avoid health hazards.

### **4.3.1 Requirements regarding untreated water (drinking water or raw water)**

The operator shall ensure that the following requirements are met on a permanent basis:

- The water must be free of particulates > 5µ
- The water has to be free from colloids and/or organic substances as a matter of principle
- Well water, rain water and VE water are not admissible
- The water must have drinking water quality (e.g. quantity of organic substances)
- The maximum number of germs may not exceed 1000 germs/ml
- It has to be free from chemical substances/additives (e.g. chlorine, ozone, disinfectants)
- No accessory devices that alter the properties of the untreated water (e.g. dosing equipment) may be used
- Water temperature **43-68°F** (6-20 °C)
- Flow pressure **43-58 psi** (2-3 bar)

Requirements regarding water treatment:

- A three-stage water treatment system has to be used
- Water softening (<0.1 °dH at the outlet)
- Filtering (mechanical filter 5 µm + activated-carbon filter)
- Demineralization by reverse osmosis (inorganic membrane)
- Water values at the outlet of the water treatment system:
  - Water hardness **< 0.1 °dH**
  - Conductivity **5-10 µS**
  - Water temperature **6-25°C** (43-77 °F)
  - Flow pressure **2-3 bar** (43-58 psi)
- The product has to be conducted in a closed system up to point where it exits the nozzle and it may not get in contact with the air in the room any time
- No water tanks with float control may be used. Closed membrane tanks made of stainless steel or plastic have to be used for intermediate storage of the product (pressure control) instead
- Fittings and tubes have to be made of materials authorized for the food industry (plastic, stainless steel). Do not use copper or brass tubes!
- The treated water has to be free from organic substances

## 4.4 Notes on compressed air supply

The operator shall ensure that the following requirements are met on a permanent basis:

- The compressed air must have **respiratory air quality** and be **free from contamination** (residual oil content < 0.003 mg/m<sup>3</sup>, dust, water, etc.)
- The **admissible inlet pressure on the wall brackets** is **max. 87 psi (without pressure fluctuations and pressure blows)**
- When dimensioning the compressor and/or the outlet pressure, possible losses via the tube network have to be taken into consideration
- It is recommended to install a micro filter and an activated carbon filter
- When a manometer and a pressure-relief device are installed in the compressed air feed, the performance of the system can be assessed more easily.

**Important!** The compressed air line has to be blown out before it is connected.

## 4.5 Notes on the run of the tubes

- Use a **suitable cutting device** guaranteeing a **straight and kink-free** cut when cutting the tubes
- The tubes may not be kinked or damaged (longitudinal grooves)
- Make sure that the tubes are **not kinked** and that a **minimum bending radius of 1.57 inches (40 mm)** is maintained
- Do not pass the tubes near warm or even hot components (**max. admissible ambient temperature 95°F (35°C)**)
- Avoid exposure of the tube to direct sunlight

In order to protect them against damage and to prevent them from sagging, the tubes have to be run between the individual components inside a protective tube, if possible.

Upon installation, check:

- Whether all tubes sit tight. It is not possible to pull out correctly mounted tubes without exercising pressure on the clamping ring
- The water and compressed air systems for tightness



### WARNING!

It is recommended to install the network of tubes in the form of a star, if possible. When the distance between the air supply and the water supply is too large, malfunctions or even problems regarding hygiene may occur. Always call Nortec customer service in case of doubt (+1 262 884 4669).

The last atomizer of a series may be at a maximum distance of 230 feet (70 metres) from the air supply and/or the water supply.

# 5 Installation

## 5.1 Safety notes on installation

Assembly and installation may only be carried out by **authorized, qualified staff** (plumbers, electricians). The person who places the order for the installation has to ensure that they are qualified accordingly.

All local rules and regulations on the execution of electrical installations and water installations must be complied with.

It is obligatory to read the notes and regulations of this chapter for adequate placement of system components, on assembly and electrical installations and to comply with them.

## 5.2 General notes on positioning

The positioning of a system is always determined during planning and noted in the system documents. The following general positioning notes, however, have to be read and complied with in any case:

- Make sure that the construction (wall, pillar, ceiling construction, etc.) on which the devices and/or system components will be mounted disposes of a **sufficient load-carrying capacity and is suitable for fixing (see Chapter 8. “Technical data“)**
- Position the atomizers in such a way to enable the aerosol mist to spread freely. When the aerosol mist is prevented from spreading by obstacles (e.g. ceilings, beams, etc.), turbulences can build up and condensation may occur as a result
- In the illustration shown in the next section, you will find the measurements of the **expansion of the aerosol stream**, and the **clearances that have to be kept**. The measurements relate to the maximum humidification capacity of the atomizer nozzles and a room temperature between 64°F and 75°F. When the temperature is higher, the expansion of the aerosol stream is reduced, when the temperature is lower, it increases
- When atomizer nozzles are installed one opposite the other, make sure that a minimum distance of 26 ft. is maintained between the nozzles in order to avoid that the aerosol streams condensate each other
- Pay attention to the airflow of the room. Do not install atomizer nozzles in the immediate vicinity of an exhaust system or of a cold-air inlet
- Do not direct atomizer nozzles at cold parts of a building, e.g. outside walls, windows, etc. (risk of condensation)
- Insulate cold-water pipes in the area of the aerosol stream (risk of condensation)
- The evaporation process absorbs heat from the ambient air. For this reason, make sure that the aerosol stream is not directed on persons or on places directly above workplaces
- In order to guarantee an optimum humidification, ensure that the atomizers are sensibly distributed in the room
- The system components have to be mounted in such a way to provide enough space for operation and maintenance

Please contact Nortec in case you have questions on positioning and clearances.

## 5.3 General notes on assembly

- Installation has to be carried out according to the general engineering rules and the connection regulations of the local utility companies
- Before the installation, check whether the delivery is complete and undamaged, using the delivery notes for this purpose
- The tubes may only be installed by certified master craftsmen that were instructed on how to proceed
- No unauthorized conversions or alterations may be carried out on the devices
- No additional fittings (e.g. valves, etc.) that are not included in the assembly plan may be installed in the Nortec system

- These assembly instructions only refer to individual systems. The manufacturer provides individual system diagrams for the customers' systems
- It is obligatory to comply with the material specifications

### 5.3.1 Standard Mounting

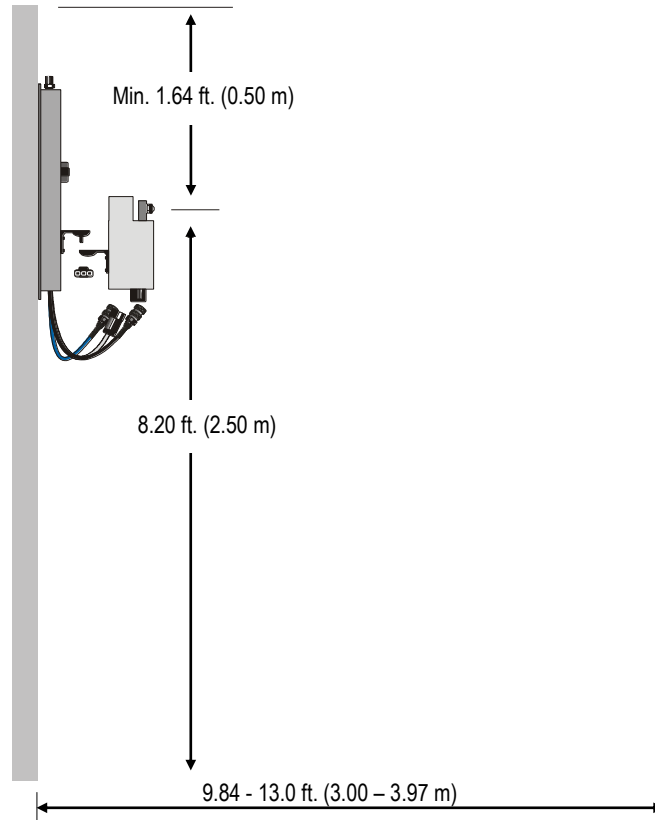

Figure 5: AF-22 wall mounting

#### Positioning of the atomizers

- Select a distance to the ceiling of at least 1.64 ft.
- Do not place the atomizers directly above a workplace
- The air space has to be free over a distance of 9.84 ft. - 13.0 ft. in an angle of 90°
- Avoid exposure of the atomizers to direct sunlight

#### Connection of the wall bracket

All AF-22 devices are connected with the quick assembly kit delivered as accessory.

The connection for treated water is made using the black PU-4 tube (create branch line to the wall bracket using the enclosed T connectors).

The compressed air tube is connected using the blue PU-9 tube (create branch line to the wall bracket using the enclosed T connectors).

The power supply from the transformer is connected via junction boxes in the form of a branch line to the relevant wall bracket. On the junction box, it is run through the cable duct of the wall bracket and connected to the enclosed plugs. The length of the cables has to correspond to the length of the tubes.

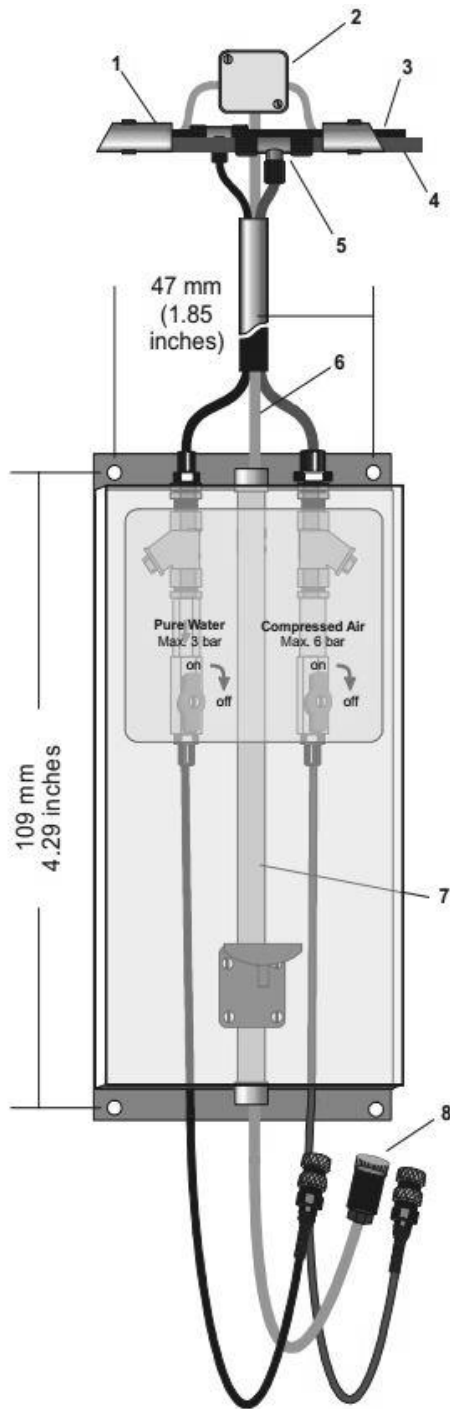

Figure 6: AF-22 Wall Bracket Connection

- |                              |                              |
|------------------------------|------------------------------|
| (1) Protective tube PG 29    | (2) Distributing box         |
| (3) Treated water tube PU-4  | (4) Compressed air tube PU-9 |
| (5) T connector              | (6) Cable HO5 VV-F-2 x 1.5   |
| (7) Cable inlet wall bracket | (8) Plug                     |



## 5.4 Electrical installation

The documentation does not cover the installation of the voltage supply. However, it does include the electrical requirements.



### CAUTION!

The layouts of the electrical installation and voltage supply have to comply with the local safety regulations and standards.

---

#### **NOTES:** Electrical installation:

It is obligatory to run the connecting cables through the cable fittings provided for that purpose in the device.



### CAUTION!

The atomizers may only be supplied with 48 VAC/50...60 Hz.

---

### 5.4.1 AF-22

The voltage supply for the atomizers is provided directly to the wall brackets (with a junction box) via the external safety transformer.



### WARNING!

Before and when working on the devices, make sure that all lines are disconnected and that the voltage supply is secured against unintentional switching on.

---

**NOTE:** The transformer must be positioned as close as possible to the atomizers in order to avoid an unnecessary loss of voltage on the lines. **You can connect a maximum of four (quantity 4) atomizers to the supplying transformer.**

A special plug is included in the scope of delivery of the wall brackets. Only this plug may be used to connect the atomizers.

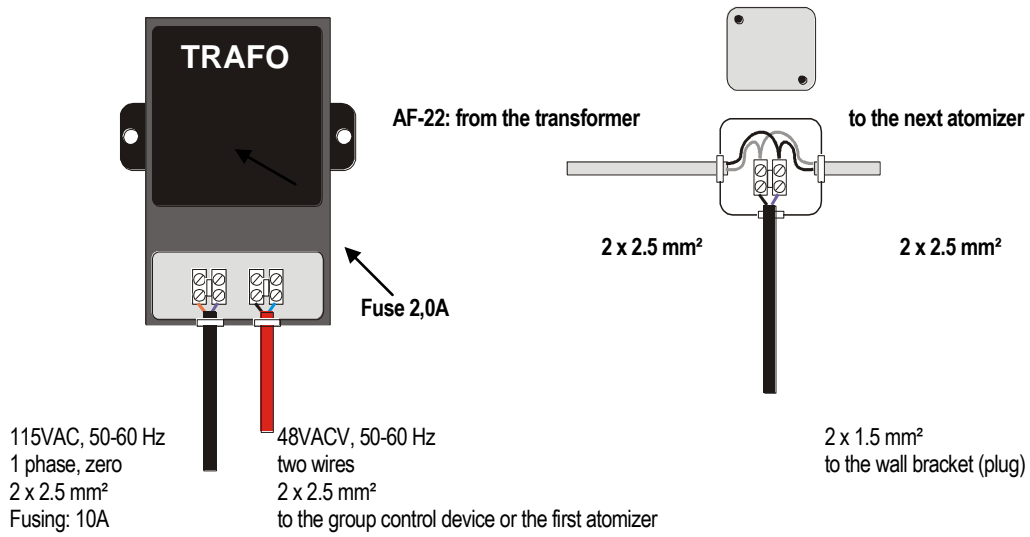

Figure 7: Electrical installation to transformer

Plug connection:  
Litz wire, black, sw      PIN3  
Litz wire, blue, bl      PIN PE

## 5.5 Material specification

### 5.5.1 Protective tube

#### Insulating material tube (protective tube)

PG 16/PG 29

Material: PVC-U  
Complies with: DIN 49016, Part 2, DIN 16929, DIN 4102  
Temperature Range: 23°F - 140°F

#### Quick clamps

Material: Polypropylene  
Temperature Range: -22°F - 194°F

Suitable for protective tube and for wall mounting.

### 5.5.2 Air tube and water tube

#### PU 4 tube, black (water side)

Material: Polyurethane  
6 x 4 x 1 mm  
Max. operating pressure: 145 psi at 68°F

#### PU 9 tube, blue (air side)

Material: Polyurethane  
12 x 9 x 1.5 mm  
Max. Operating pressure: 101 psi at 68°F

#### Plastic coupling pieces

Material: POM  
Pressure range: 0 - 10 bar  
Temp. range: 14°F - 140°F

Suitable for PU tube, black and blue.

### 5.5.3 Cables

#### Type 1

Use: Voltage supply from domestic mains to external transformer  
Description: H05 W-F 2 x 1.5 mm<sup>2</sup>  
Fusing (domestic mains): 10A, slow-to-blow

#### Type 2

Use: From external transformer to atomizers and/or group control unit.  
From group control unit to atomizers, in addition.  
Description: H05 W-F 2 x 2.5 mm<sup>2</sup>  
Fusing (in transformer): 2.5A, slow-to-blow

## 6 Operation

The Nortec AF-22 humidifier must only be operated by personnel who are adequately qualified, well trained and are authorized by the customer.

### 6.1 Switching-off during daily operation

For maintenance, the replacement of defective, faulty system components or required, it may be necessary to take the system out of operation. More information on when to disconnect the system is included in Chapter 7 (see also the **replacement instructions** for the individual components).



#### WARNING!

When switching off the system, always ensure a thorough and complete disconnection and draining of the system (water supply and voltage supply, depending on the type of disconnection). The employees have to be informed about the disconnection.

#### 6.1.1 Switching-off completely

The humidification system can be partially or completely disconnected, and the water supply is switched off.

##### Atomizer AF-22:

Remove the voltage supply plug from the device. The water supply and/or the compressed air supply can also be interrupted in addition by removing the quick couplings.



#### WARNING!

Please note that there is a risk of stagnant water contamination when it is switched off for a longer time period, more than 24 hours (fresh water automatic system not active). It is obligatory to inform Nortec customer service before switching the system off completely.

#### 6.1.2 Partial switching-off

Adjust the set-point to 20% RH. In this case, the fresh water automatic system is still active.



#### WARNING!

You can also disconnect the water supply and/or compressed air supply of the atomizers by removing the quick couplings in order to stop the device from working. This may only be done **in an emergency**. Please note that there is a risk of stagnant water contamination when it is switched off for a longer time period (more than 24 hours) (fresh water automatic system not active).

## 6.2 Setting to operation on a daily basis

Depending on whether a partial or complete switching-off was performed, switching-on has to be performed in reverse order (see also the **replacement instructions** for the individual devices).

First connect the water supply and/or the compressed air supply (quick couplings). Then connect the voltage supply (plug). Now you can adjust the set-point to the desired value again on the AF-22.

## 6.3 Routine checks

When irregularities or malfunctions are detected during checks, inform Nortec customer service at once. Routine checks may only be carried out by authorized staff. The operator is responsible for checking the suitability of the staff and for instructing them.

### 6.3.1 Atomizer AF-22

Assess the spray pattern. The ratio water consumption/compressed air consumption has a considerable influence on the spray pattern. These parameters can be set on the device. Work settings may never be changed without prior consultation of Nortec customer service.

**Cycle: Every 2 weeks**

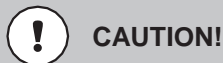

The routine check is necessary because it is possible to prevent damage when a very bad atomization process is detected in time. The worse the atomizing result, the bigger the drops. Drops falling down may cause damage by corrosion.

In areas with a lot of dust and/or dirt formation, the functioning of the atomizers may be impaired. Check this and remove the dirt, if necessary. Deposits on the nozzles may impair the spray pattern. You can try to clean them as follows as an emergency measure:

Disconnect the device and switch off the valves for air and water. Remove the knurled thumb screw (3) and the air cap. Remove deposits at the tip of the nozzle (1) using a soft, lint-free cloth. Never use a needle or similar solid objects for cleaning!

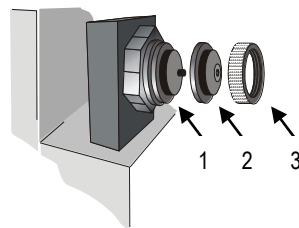
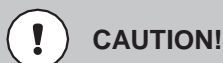

Figure 8: Atomization checks and nozzle cleaning

**Cycle: Every 4 weeks**



Do not clean with water or any kind of cleaners, but **only vacuum it**. Disconnect the device and protect against switching on before cleaning.

# 7 Replacement of components

Please inform Nortec customer service when you notice a malfunction on the system.

## **Nortec Humidity Ltd**

**Spare Parts** (Mon. – Fri.)  
8:00 a.m. – 5:00 p.m.

Phone: +1 262 884 4669

**Customer Service** (Mon. – Fri.)  
8:30 a.m. – 4:30 p.m.

Phone: +1 866 667 8321

The replacement is to be made only by instructed, trained personnel. The operator is obliged to ensure that the personnel is suited, has been instructed and trained as required. He is obligated to comply with the instructions of Nortec in the process, especially the instructions contained in this documentation.



### **CAUTION!**

Please inform the people working nearby, that work will be carried out on the air humidification system. Make sure that the system cannot be switched on unintentionally.

---

## Atomizer AF-22 component replacement

1. Close the shut-off valves **(5)** on the wall bracket.
2. Pull off the plug couplings **(3)** and **(1)** for compressed air and water. Press down the knurled ring and then pull out the plug couplings downwards in order to do that.
3. Pull off the plug **(2)**. Loosen the knurled ring on the plug by turning it anti-clockwise and pull out the plug downwards.
4. Remove the atomizer by unscrewing the star knob screw **(4)** and attach the new atomizer.
5. Connect the new atomizer in reverse order (Do not connect the supplying lines crosswise!). Adjust the desired set point, (for example 50% RH) on the hygostat. Adjust the atomizer by means of the star knob screw **(4)**.

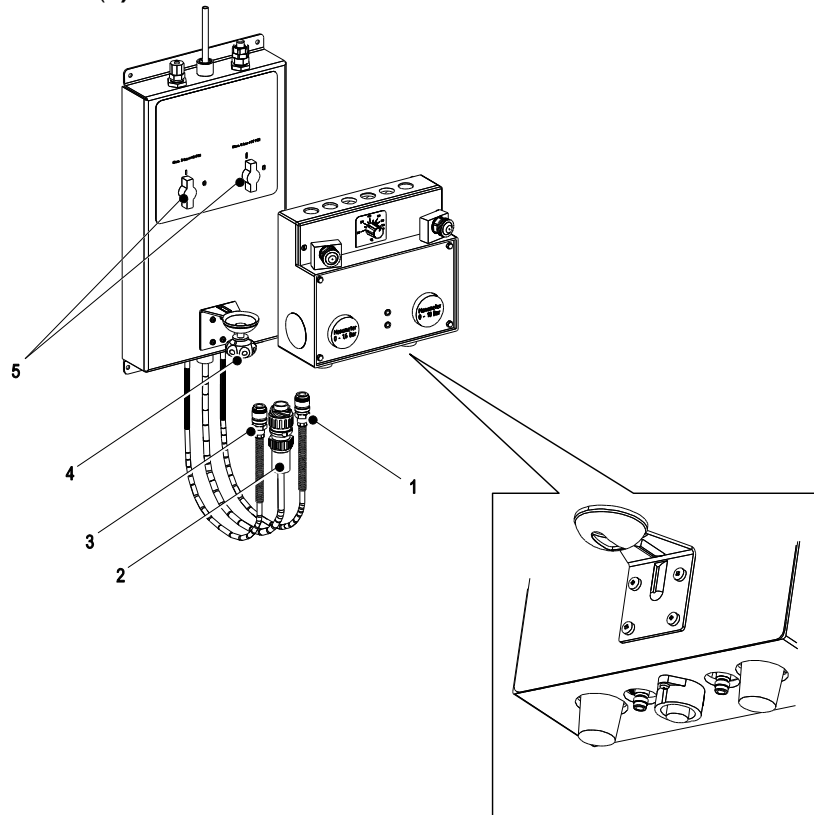

Figure 9: AF-22 bracket connection to atomizer box

## 8 Technical Data

Table 2: AF-22 Technical Specifications

Specification data	
Capacity	22 lbs/hr (10 kg/hr)*
Compressed air requirements	60 Nlm
Working pressure air / water	43.5-58.0 psi/2.9-5.9 psi* <sup>1</sup>
Dimensions (w x h x d)	8.26 in x 21.75 in x 9.84 in
Weight	6.1 lbs (2.8 kg)
Operating voltage	48 VAC, 50 Hz, ±10%
Power input	20 W
Overvoltage category	II
Pollution degree	2
Application	Inside only
Height above sea level	6,670 ft. (2,000 m)
Ambient temperature	44-95 °F (7-35°C)
Ambient humidity	Max. 80 %, prevent condensation

\*: Depending on the set water / air ratio

\*1: factory settings



# 9 Appendix

## 9.1 Spare Parts / Options

Table 3: Spare Parts List

Part Number	Part Name	Description
2523539	Wall mounted Gauge & Filter Rail	Water filter
2577587	LPES 1000 RO System	Reverse osmosis system
2300194	62 Gallon Repo. Tank	Reverse osmosis water holding tank
52003	AF-22 Pure Water Atomizer (Head)	Main head with atomization nozzles
9558	Biosafe transformer	AF-22 spare or extra 48V transformer
25005	Low Pressure Hose (air) – PU 9 Blue	Compressed air extra hose
25004	Low Pressure Hose (water) – PU 4 Black	Water supply extra hose

## 9.2 AF-22 Humidification Load Calculation Examples

### 9.2.1 Example 1 (AF-22)

In this case, only one room is to be humidified. As every atomizer is fitted with its own hygostat, different zones within one area (room) can be humidified individually.

#### EXAMPLE 1

A Nortec AF-22 for direct room air humidification is to be installed in the paper store of a large printing works. The following data is available:

Room measurements (l x w x h) in ft.:	98.0 x 66.0 x 11.5
Number of air changes per hour:	2.2
Outside air conditions in winter:	5°F/ 90 % RH
Desired room temperature:	70°F
Desired relative air humidity:	53 % RH
Areas:	One

### 9.2.1.1 Calculating the maximum humidification capacity

The maximum humidification capacity is calculated using the following formula:

$$m_{H_2O} = \frac{V \times 1.0 \times AE/h \times (X_2 - X_1)}{A \times V_1}$$

- $m_{H_2O}$**  : Maximum humidification capacity in **lb/h**  
**V** : Air volume to be humidified in **ft<sup>3</sup>** (formula: L x W x H)  
 **$V_1$**  : Specific volume of air at set point in **ft<sup>3</sup>/lb**  
**AE/h** : Number of air changes per hour

The number of air changes per hour depends on the usage of the room and must be determined by the system planner as part of the planning process. The following guide values can be taken as the basis:

- Textile processing: 3 – 7 AE/h
- Printing works: 2 – 5 AE/h
- Storerooms: 1 – 3 AE/h
- Cooling rooms: max. 1 AE/h

- 1.0** : Fixed value for the specific weight of the air in **lb/ft<sup>3</sup>**  
**A** : Fixed value (7,000) for the conversion of pounds to grains in **grains/lb**.  
 **$x_2$**  : Desired absolute humidity of the air in the room in **grains/lb**  
 **$x_1$**  : Minimum absolute humidity y before humidification in **grains/lb**

#### **NOTES:**

Where outside air represents 100 % of the air, the outside air condition in winter must be applied. If there is an air circulation system (30 % outside air, 70 % recirculated air), the resulting air mix must be applied.

For the values for  **$x_2$**  and  **$x_1$**  refer to the **psychrometric chart** in the appendix.

#### **NOTES:**

The formula takes no account any absorption or discharge of humidity by materials in the humidified room.

#### **SOLUTION EXAMPLE 1**

In this example, a humidification capacity of **101 lbs/h** is required.

In case of questions regarding the calculation of the humidification capacity, please contact Nortec.

### 9.2.1.2 Determining the device requirements

Now the decisive value of the necessary humidification capacity is available for the determination. The following notes on the capacity of the atomizers provide a second basis.

Capacity AF-22      22 lbs/h

**EXAMPLE 1 (continued)**  
*Total water volume (mH<sub>2</sub>O) = 101 lbs/h*  
*Required:*  
*5 units AF-22*  
*1 unit transformer*

The tube requirements for air supply and power supply depend on the cable. They are determined on the basis of the ground plan. The result for this example is **approx. 230 ft.** of Nortec quick assembly kit (**SMB**). The SMB comes with the necessary cables, low-pressure tubes and fittings. For further notes on the tube run, please see Chapter 4.3-4.5.

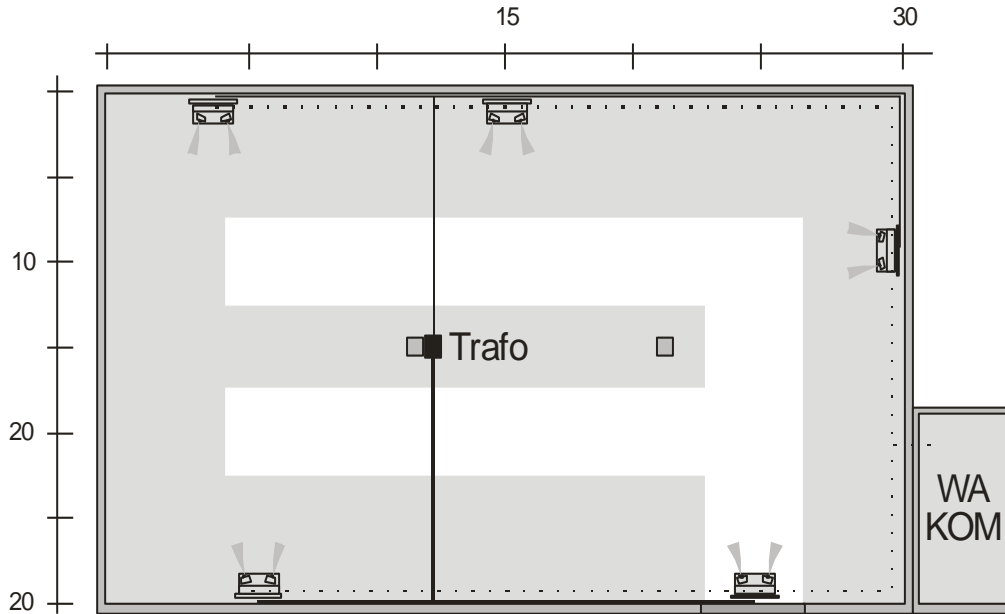

Figure 10: Example 1 schematic

The solid line stands for power supply, the dotted line for air and water supply. Dimension scale is shown in metres.

WA: Water treatment (if necessary)  
KOM: Compressor

**IMPORTANT:** Make sure to connect **no more than six (6) AF-22 to one string** when planning the supply network for the atomizers (water and compressed air). Malfunctions may occur if more than six (6) devices are connected. To avoid malfunction - two further strings must be created for splitting up the string (see sketch above).

### 9.2.1.3 Determining the compressed air and water requirements

#### Compressed air requirements:

The compressed-air consumption of a system depends on the number of atomizers and is calculated using the following formula:

$$Q_L = n_D \times 2.119 \text{ CFM}$$

$$Q_L = n_D \times 60 \text{ L/min}$$

$Q_L$ : Necessary air volume in GPM (l/min)  
 $n_D$ : Number of devices

Related to the **example** and using the following values:

$$n_D = 5$$

The result is an air volume of **10.6 CFM** (300 l/min).

**NOTE:**

In order to ensure a trouble-free operation, the compressed-air system must deliver 1.2 times the air volume that has been calculated.

Water requirements:

The water requirements of a system depend on the number of atomizers and are calculated using the following formula:

$$Q_w = n_D \times 22 \text{ lbs/hr}$$

$Q_w$ : Necessary water in lbs/h  
 $n_D$ : Number of devices

Related to the **example** and using the following values:

$$n_D = 5$$

The result is a water volume of **110 lbs/h**.

**NOTE:** In order to ensure a trouble-free operation, the water system must deliver 1.2 times the maximum water volume that has been calculated.

## 9.2.2 Example 2 (AF-22 in multiple areas)

The areas of humidification were determined on the basis of the room plan.

### EXAMPLE 2

A Nortec air humidification system for a direct humidification of the indoor air is to be installed in a large printing works. The following data is available (index 1 for area 1, index 2 for area 2):

Room (l x w x h) in ft.:	130.0 x 98.0 x 13.0
Area 1	98.0 x 98.0 x 13.0
Area 2 (suspended ceiling)	33.0 x 98.0 x 13.0
Number of air changes per hour:	3.01, 1.52
Outside air conditions in winter:	5°F/ 90 % RH
Desired room temperature:	70°F
Desired air humidity:	53 % RH
Areas:	Two

### 9.2.2.1 Calculating the maximum humidification capacity

The calculation is carried out as described under 9.2.1.1.

### SOLUTION EXAMPLE 2

For the example area 1, the result is a necessary humidification capacity of **236 lbs/h**. For the example area 2, the result is a necessary humidification capacity of **40 lbs/h**.

### 9.2.2.2 Determining the device requirements

AF-22 Capacity = 22 lbs/h (10 kg/h)

**EXAMPLE 2 (continued)**

For area 1:  
11 units AF-22

For area 2:  
2 units AF-22  
4 units transformers (total)

The tube requirements for air and water supply depend on the tube run. It is determined on the basis of the ground plan. For this example, the result is **approx. 525 feet (160 m)** of Nortec quick-assembly kit (**SMB**). The SMB includes the necessary cables, low-pressure tubes and fittings. For further information on the tube run, please see Chapter 4.3-4.5.

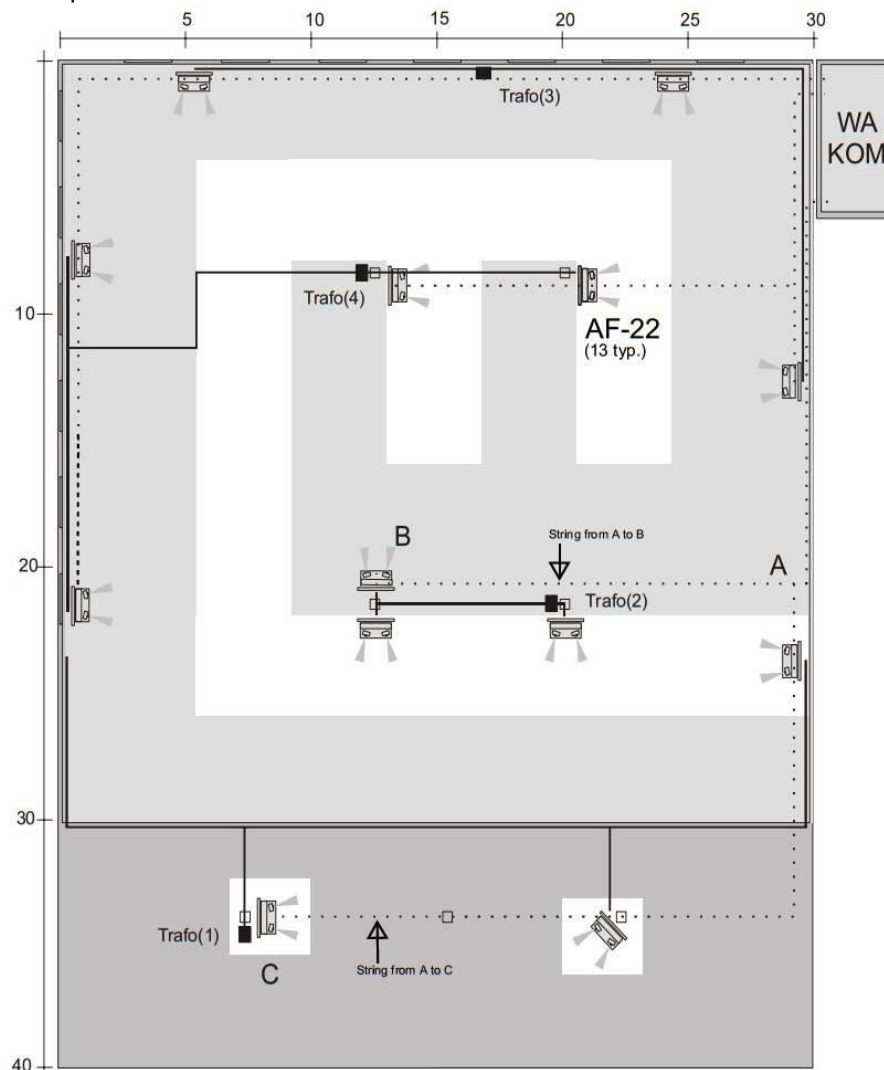

Figure 11: Example 2 schematic

The solid line stands for power supply, the dotted line for air and water supply. Dimension scale is shown in metres.

WA: Water treatment, if necessary  
KOM: Compressor

### 9.2.2.3 Determining the compressed air and water requirements

#### Compressed air requirements

The compressed air consumption of a system depends on the number of atomizers.

AF-22: 2.119 CFM (60 NL/min)

Related to the **example** and using the following values:

Area 1 = 300 lbs/hr (660 L/h)

Area 2 = 54.54 lbs/hr (120 L/h)

The result is an air volume of **1716 lbs/hr (780 l/h)**

#### **NOTE:**

In order to ensure a trouble-free operation, the compressed air system ought to deliver 1.2 times the air volume that has been calculated.

#### Water requirements

The water consumption of a system depends on the number of atomizers.

AF-22: 22 lbs/h

Related to the example and using the following values:

Area 1 = 243 lbs/h

Area 2 = 44 lbs/h

The result is an air volume of **287 lbs/h.**

#### **NOTE:**

In order to ensure a trouble-free operation, the water system ought to deliver 1.2 times the maximum water volume that has been calculated.

### 9.3 Psychrometric Chart (Imperial)

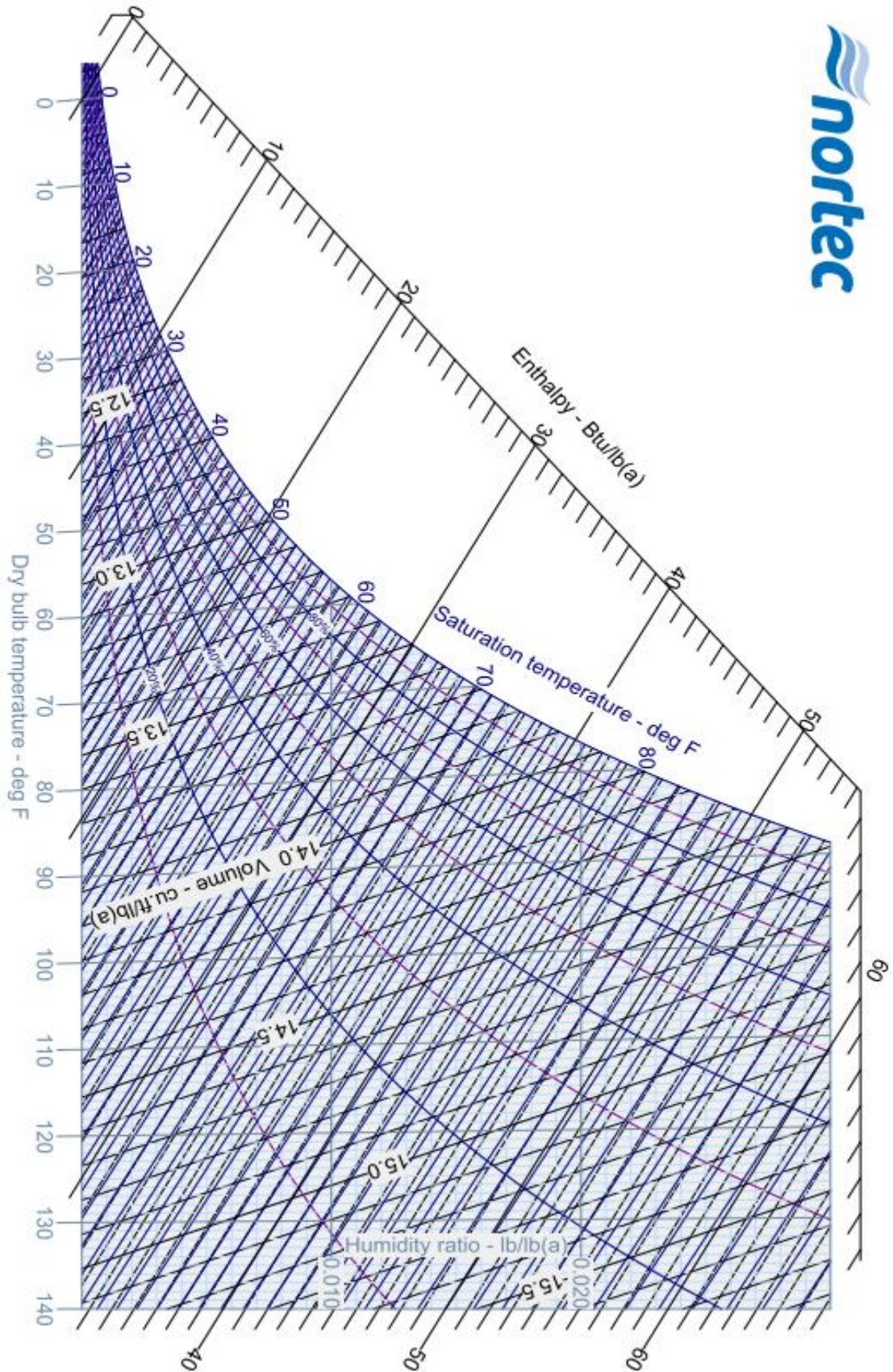

## 9.4 Psychrometric Chart (Metric)

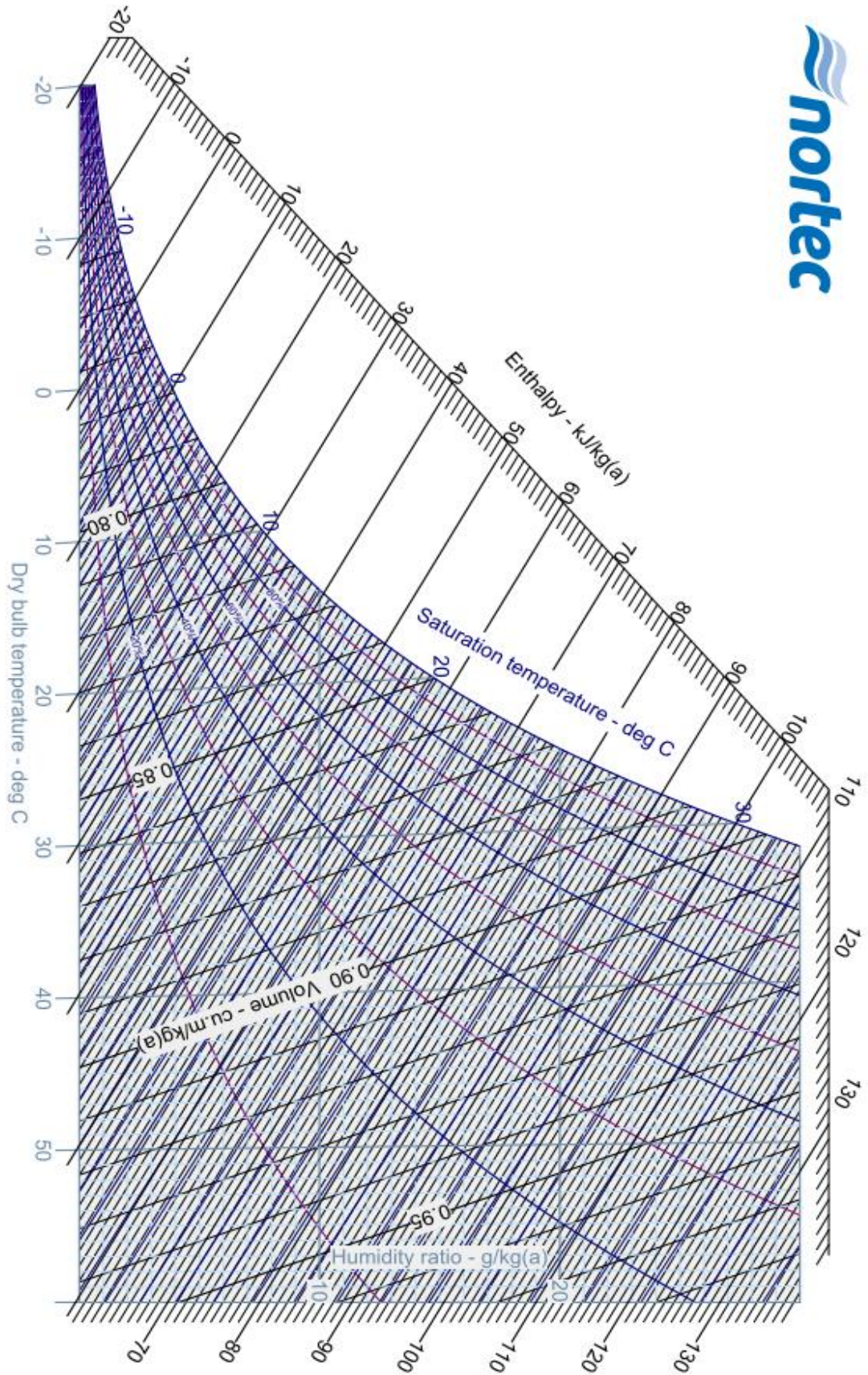



# Warranty

---

Nortec Humidity Inc. and/or Nortec Humidity Ltd. (hereinafter collectively referred to as THE COMPANY), warrant for a period of two years after installation or 30 months from manufacturer's ship date, whichever date is earlier, that THE COMPANY's manufactured and assembled products, not otherwise expressly warranted (with the exception of steam cylinders), are free from defects in material and workmanship. No warranty is made against corrosion, deterioration, or suitability of substituted materials used as a result of compliance with government regulations.

THE COMPANY's obligations and liabilities under this warranty are limited to furnishing replacement parts to the customer, F.O.B. THE COMPANY's factory, providing the defective part(s) is returned freight prepaid by the customer. Parts used for repairs are warranted for the balance of the term of the warranty on the original humidifier or 90 days, whichever is longer.

The warranties set forth herein are in lieu of all other warranties expressed or implied by law. No liability whatsoever shall be attached to THE COMPANY until said products have been paid for in full and then said liability shall be limited to the original purchase price for the product. Any further warranty must be in writing, signed by an officer of THE COMPANY.

THE COMPANY's limited warranty on accessories, not of the companies manufacture, such as controls, humidistats, pumps, etc. is limited to the warranty of the original equipment manufacturer from date of original shipment of humidifier.

THE COMPANY makes no warranty and assumes no liability unless the equipment is installed in strict accordance with a copy of the catalog and installation manual in effect at the date of purchase and by a contractor approved by THE COMPANY to install such equipment.

THE COMPANY makes no warranty and assumes no liability whatsoever for consequential damage or damage resulting directly from misapplication, incorrect sizing or lack of proper maintenance of the equipment.

THE COMPANY makes no warranty and assumes no liability whatsoever for damage resulting from freezing of the humidifier, supply lines, drain lines, or steam distribution systems.

THE COMPANY retains the right to change the design, specification and performance criteria of its products without notice or obligation



Consulting, Sales and Service:

**U.S.A.**  
835 Commerce Park Ave.  
Ogdensburg, NY 1366-2209

**CANADA**  
2740 Fenton Road  
Ottawa, ON, K1T 3T7

Tel. 1.866.NORTEC1  
Fax: 613.822.7964

Email: [nortec@humidity.com](mailto:nortec@humidity.com)  
Website: [www.humidity.com](http://www.humidity.com)

