

# HUVF Series Duct Mounted UV System

## PRODUCT DATA



## FEATURES

- Suitable for mounting in AHU near Cooling coil.
- Plug and Play design enables ease of installation.
- Effective on all types of pathogens.
- HUVF58C2000 / HUVF58S2000: 2 Lamps - 23W max. each.
- HUVF58C1000 / HUVF58S1000: 1 Lamp - 23W max.
- Effective in IAQ improvement.
- Effective deactivation of viruses and bacteria killing with 254 nm wavelength UVC.
- Effective in reducing microbe generated VOCs in AHU.

## APPLICATION

Honeywell HUVF Series is designed for installation inside the air handling units or ductwork of the HVAC system for the purpose of surface disinfection using ultraviolet germicidal irradiation. This system uses UV-C technology which is effective in killing mold, bacteria and viruses. This system is effective in coil cleaning and helps in maintaining the cooling coil efficiency. This UV based system is effective in deactivating the microbes and improving the overall indoor air quality by reducing the microbial load on the indoor air.

## SPECIFICATIONS

**Model:** See Table 1.

**Electrical Ratings:**

Power Consumption: See Table 1.

Voltage Rating: 230 Vac  $\pm$ 10%, 50/60 Hz

**Operating Environment:**

Temperature: 5 °C to 40 °C

Humidity: 0 to 90% RH (non-condensing)

**Mounting:**

Mounts into the AHU between the pre-filters and cooling coils with lamps facing the cooling coils.

## Contents

Application .....	1
Features .....	1
Specifications .....	1
Planning the Installation .....	3
Installation .....	4
Wiring .....	5
Operation and Maintenance .....	5
Service .....	6
Electrical Troubleshooting .....	7
Parts List .....	7



**Weight:**

Shipping Weight:  
 Single Lamp: 8.6 kg  
 Dual Lamp: 13 kg  
 Installed Weight:  
 Single Lamp: 5 kg  
 Dual Lamp: 8 kg

**Dimensions:**

See Fig. 1. and Fig. 2.  
 Lamp Length: 500 ± 3 mm  
 Lamp Diameter: 15 mm

**Lamp Connector:** 4 Pin

**Lamp Wattage:** 23 W

**Lamp Current:** 425 mA

**Lamp Life:** 12,000 hours

**Wavelength:** 253.7 nm

**Cumulative Average Intensity:** 4647 μW/cm<sup>2</sup>, using regular lamps under standard conditions.

**Ballast Type:** High frequency electronic

**Repair Parts:** See Table 2.

**Regulatory Approvals:** CE, RoHS



**IMPORTANT**

*This symbol on our product shows a crossed-out “wheelie-bin” as required by law regarding the Waste of Electrical and Electronic Equipment (WEEE) disposal. This indicates your responsibility to contribute in saving the environment by proper disposal of this Waste, i.e. do not dispose of this product with your other wastes. To know the right disposal mechanism please check the applicable law.*

**Table 1. HUVF Series Models.**

Model	Lamp Type	Lamp Quantity	Unit Wattage	Capacity
HUVF58C1000	Regular	1	25 W	1000 CFM (1700 m <sup>3</sup> /hr)
HUVF58C2000		2	50 W	2000 CFM (3400 m <sup>3</sup> /hr)
HUVF58S1000	Shatterproof	1	25 W	1000 CFM (1700 m <sup>3</sup> /hr)
HUVF58S2000		2	50 W	2000 CFM (3400 m <sup>3</sup> /hr)

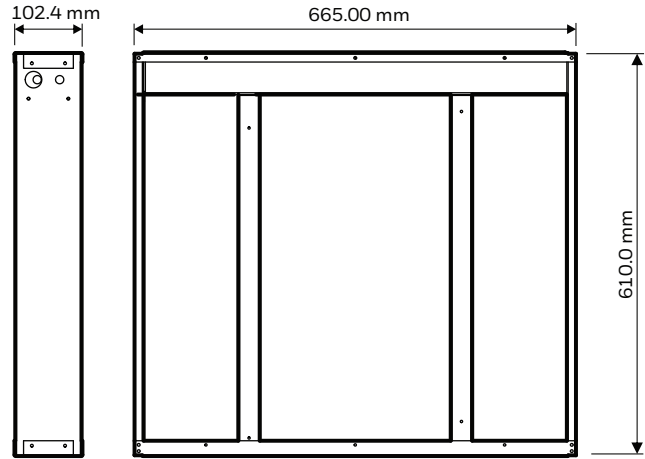

**Fig. 1. Dual lamp HUVF Series dimensions.**

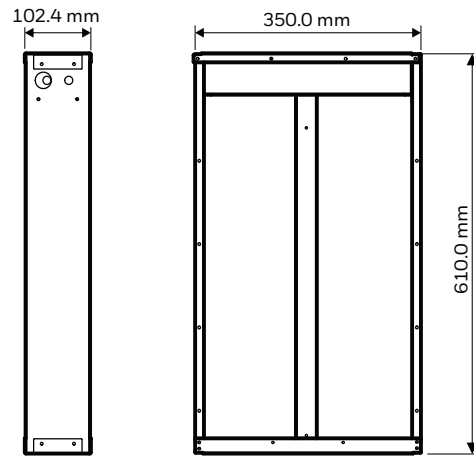

**Fig. 2. Single lamp HUVF Series dimensions.**

## PLANNING THE INSTALLATION

**NOTICE:**

- Read the maintenance instructions before opening the appliance.
- Appliances that are obviously damaged must not be operated.
- UV-C BARRIERS bearing the ULTRAVIOLET RADIATION hazard symbol should not be removed.
- Do not operate UV-C LAMPS outside of the appliance.

## Choosing a Mounting Position



### CAUTION

**Equipment Damage Hazard.**

Ultraviolet light can cause color shift or surface degradation and sometimes structural degradation of non-metallic components. Select mounting location that prevents exposure to plastic flexible duct components, polyurethane foam insulation material, rubber hoses, wire insulation, etc. If mounting options are limited, items above should be protected with ultraviolet resistant material such as aluminum foil, aluminum duct tape, or metallic shields or the equivalent.

The HUVF Series is used in forced air heating, cooling, or ventilating systems. The system is mounted in the air handling unit (AHU) or ductwork where there are cooling coils or other surfaces that require ultraviolet treatment. When used in an AHU, the installation shall be done between the pre-filters and cooling coil in such a way that the lamps are facing towards the cooling coil.

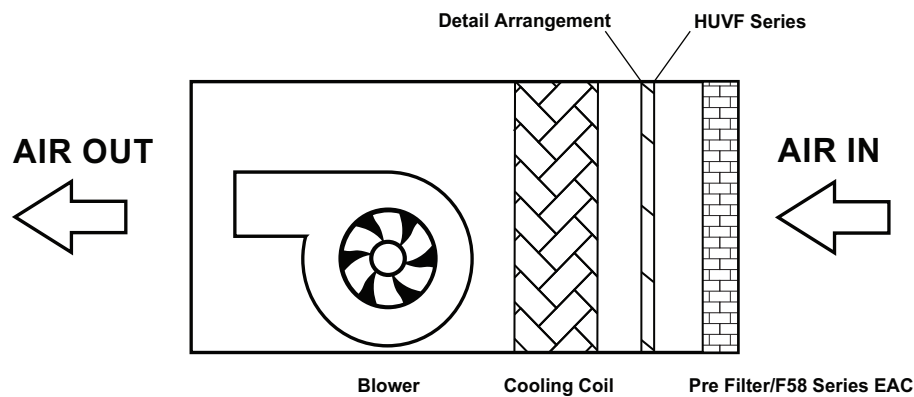
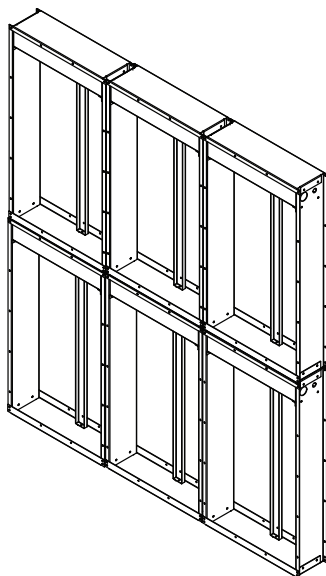

**Fig. 3. HUVF positioning inside AHU.**

## Constructing the Array

Multiple systems can be nut and bolted to each other, either side by side or on top of other, to fill the cross section of the ductwork or air-handling unit where the UV system is being installed. If each system is individually supported by the array support structure it is not necessary to connect the systems to each other. The system can be connected to each other as shown in the diagram below. Two or more systems can be connected side by side, and when required multiple rows can be placed on top of each other.

The male and female connectors are used for powering the systems. A common 230 Vac single phase power source shall be used for powering the array. The power shall not be turned 'ON' until all the mechanical fitment is finished, refer to WIRING section at the end of installation for mains power connection.



**Fig. 4. Array detail view.**

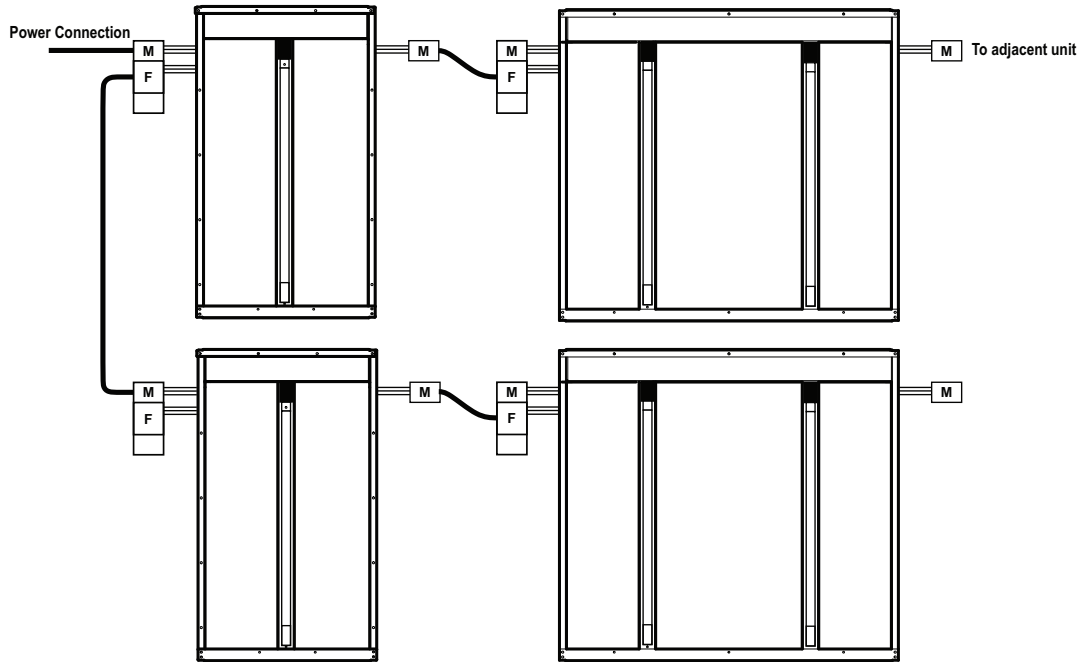

Fig. 5. Array interconnections.

## Constructing Array Support Structure

### ⚠️ WARNING

#### Construction Collapse Hazard.

Can cause personal injury or equipment damage. Provide adequate structural support to prevent array collapse. Support each unit with external structural elements across both top and bottom and add cross supports, as needed.

Provide adequate array support to prevent collapse:

- Provide minimum of external structural support across the top and bottom of each unit.
- Provide cross supports, as needed.

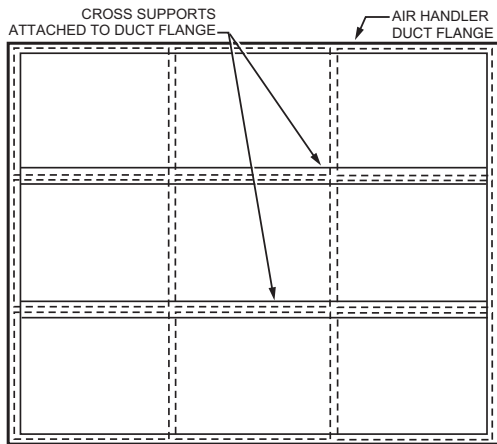

M13457

Fig. 6. Array support structure.

### ⚠️ WARNING

#### UV Light Hazard.

Harmful to bare skin and eyes.



Can cause temporary or permanent loss of vision.

Do not look at the UV lamp when lighting is on. Use indicator light on the ballast to check status. In order to prevent exposure to UV light, before repair of any parts of HVAC system, shut off power supply to UV system. Do not install in a position where UV lamp is visible during normal operation of HVAC equipment.

## INSTALLATION

### When Installing This Product...

1. The UV system is designed only for use inside Air Handling Units (AHU) and Air ducts. The units must not be used in any other location or manner. The manufacturer will not be responsible for the performance of the system or any hazard to health by its use in an unintended manner.
2. The UV system must be installed inside the AHU or air duct. An interlock switch to turn off the UV system should be provided during installation that turned off the UV system in the event the AHU is opened or accessed to prevent exposure to humans.
3. Proper PPE and UV eye protection to be used during installation of the system, UV rays are harmful to the human skin and eyes, care must be taken to ensure no direct exposure.
4. Testing of lamps other than once installed inside an AHU fitted with an interlock switch should only be done inside custom built fully enclosed test equipment.
5. The installation, service and maintenance of the system must be carried out by the qualified personnel of authorized representative.

## Connect the Lamps

### **! WARNING**

**Breakable Glass Hazard.  
Can cause personal injury.**  
Be careful when inserting bulb(s) into lamp base.  
Wear protective gloves when handling the bulb(s).

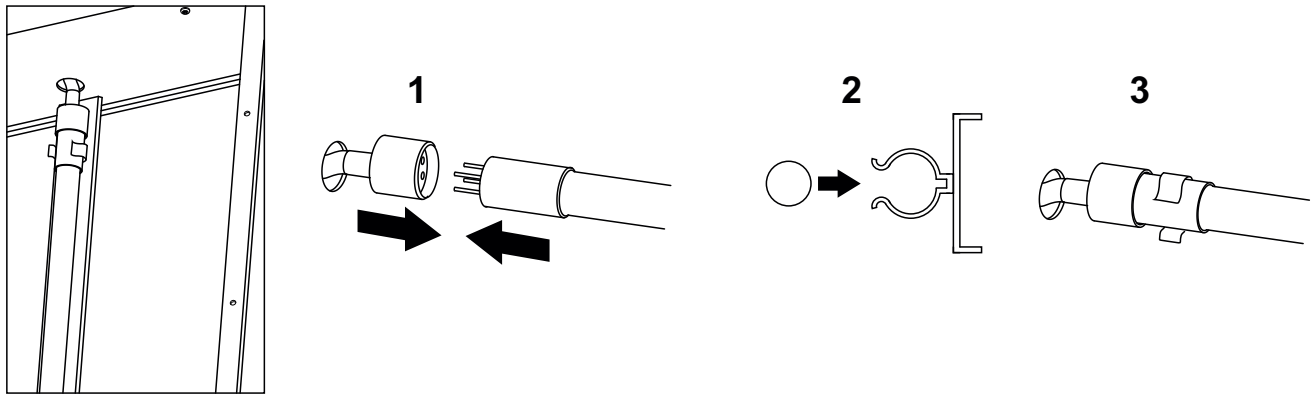

Fig. 7. Bulb connection.



### **MERCURY NOTICE**

This device contains mercury in the sealed ultraviolet bulb(s). Do not place your used bulb(s) in the trash. Dispose of properly.

Make sure that the UV lamp is connected properly to the 4-pin holder and is fixed in the clamps provided on the reflector as shown in Fig. 7 below.

## WIRING

### **! WARNING**

**Main power supply must be secured with interlock on the AHU door.**

The electrical supply circuit connected to this UV appliance must be routed through an electrical interlock switch placed on the HVAC system duct access panels and doors to prevent accidental UV exposure when servicing the air ducts or equipment. Interlock shall break all supply conductors.

- Power supply wiring system shall provide a disconnect switch for all poles.
- Assure all wiring complies with local codes and ordinances.
- Wire the UV system directly to the correct voltage and frequency electrical source. See Fig. 8.
- Install extension box, with cover, for all external plugs and wiring connections.
- This appliance incorporates an earth connection for functional purposes only.

## Power Connections

1. Decide which end of the installed array is most accessible for wiring.
2. Cut off the plastic connector for each row of air cleaners on the end selected.
3. Install an extension box to the end of each row of air cleaners.
4. Connect power and ground leads to each row of air cleaners.
5. Install cover on each box.

6. Install box and cover over power connector on opposite end of each row.

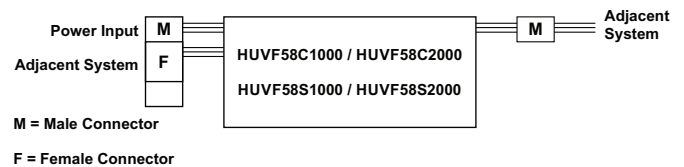

Fig. 8. Power connection to HUVF.

## OPERATION AND MAINTENANCE

### **NOTICE:**

- Service of the product to be done by authorized representative only
- Operated and serviced by qualified personnel
- No interlocks under any circumstance are defeated
- All safety measures recommended are followed as prescribed
- Provided all control measures are implemented at the user site for safety as per the Risk analysis document.
- Any internal part of the assembly shall not be removed for independent use for other applications.

During normal operation make sure that the electrical supply circuit connected to this UV appliance must be routed through an electrical interlock switch placed on the HVAC system duct access panels and doors to prevent accidental UV exposure when servicing the air ducts or equipment” or equivalent. “Interlock shall break all supply conductors.

During normal operation the lamps need to be cleaned once or twice in a month to make sure that there is no dust accumulation on the lamp surface. This cleaning can be done by normal wiping cloth or tissue paper. Make sure that the lamp mounted on the reflector clips is tight enough so that it remains in the same position before and after cleaning.

Do not pour / splash / spill water on the system and lamps during the coil cleaning. In case of accidental spillage of water on the system make sure that the system is wiped with a dry cloth to remove the water droplets. Do not switch ON the UV system immediately, instead run the blower and the HVAC system for some time (15-20 minutes) and then switch ON the UV system.

Replace as per lamp life issued in the documentation.

## SERVICE

### Lamp Replacement

#### WARNING

**Breakable Glass Hazard.  
Can cause personal injury.**

Be careful when inserting bulb(s) into lamp base. Wear protective gloves when handling the bulb(s).



#### MERCURY NOTICE

This device contains mercury in the sealed ultraviolet bulb(s). Do not place your used bulb(s) in the trash. Dispose of properly.

The UV lamps are rated for 12,000 hours of germicidal effectiveness. The visible blue light will continue to illuminate but does not have any germicidal effectiveness. Bulbs must be replaced on schedule for the system to function properly.

#### IMPORTANT

*Use only Honeywell replacement lamps. Use of replacement lamps from other manufacturers voids the warranty. See Table 2 for replacement lamp part numbers.*

For replacing the lamp(s) on the HUVF series first disconnect the power of the system. Remove the 4-pin holder on top of the lamp by pulling the lamp out of the

fixture clamps. Connect the new lamp in the 4-pin holder and fix the lamp in the SS clamps. Refer to Fig. 3 in the INSTALLATION section.

### Ballast Replacement

Refer to internal wiring diagrams.

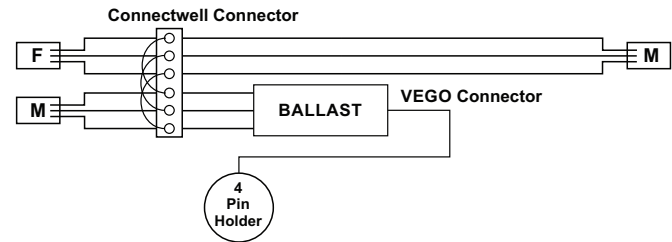

**Fig. 9. Wiring diagram for HUVF58C1000 and HUVF58S1000.**

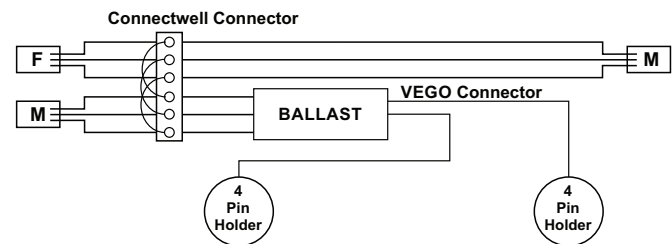

**Fig. 10. Wiring diagram for HUVF58C2000 and HUVF58S2000.**

Disconnect the line, neutral, earthing wire and lamp wires from the ballast making note of the color code and position of each wire. Back out the screws and remove the old ballast from the L plate.

After removing the old ballast place new ballast on the L plate and replace the mounting screws. Reconnect the power and lamp cable wires as per color coding. Ballast replacement is complete.

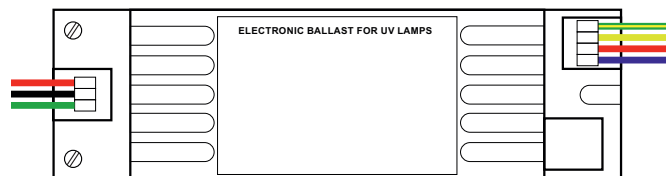

**Fig. 11. Ballast Wiring.**

# ELECTRICAL TROUBLESHOOTING

## WARNING

### Electric Shock Hazard.

Can cause personal injury or equipment damage. The following procedures expose hazardous live parts and are for use only by qualified personnel. Disconnect power between checks and proceed carefully.

## Tools and Equipment

Tools to be used for electrical troubleshooting:

- Continuity tester.
- PPE Kit

## PARTS LIST

Table 2. HUVF Parts List.

Model	Lamp	Lamp Qty.	Ballast	Holder
HUVF58C1000	HUVL58C0000	1	HUVB5801000	HUVB58K1000
HUVF58C2000		2	HUVB5802000	
HUVF58S1000	HUVL58S0000	1	HUVB5801000	
HUVF58S2000		2	HUVB5802000	

## Troubleshooting Procedure

The power supply to the system is connected using plug and play connector arrangement. Make sure that proper PPE are used before start of any testing. Please note that UV is harmful to human being and hence the system must have interlock with the access door, so that when the access door is opened the system power supply will cut. All the systems installed inside the AHU will be powered up by the single power cable. Please disconnect the power supply before servicing the unit.

Check the input power cable looping using continuity tester and confirm that all the looping wires show continuity during power off condition. Make sure that interlock is in place once the servicing is completed. Once the access door is closed, switch ON the power supply so that system starts working again.

**Honeywell Building Technologies**

Honeywell International (India) Pvt. Ltd.  
1120-21, 11th Floor, Tower A, DLF Tower  
Jasola District Centre  
Jasola, NEW DELHI, 110025, India  
1-800-103-4761

**Honeywell Building Technologies**

Honeywell GmbH  
Böblinger Strasse 17  
71101 Schönaich, Germany  
Phone +49 (0) 7031 637 01  
Fax +49 (0) 7031 637 740  
[buildings.honeywell.com](http://buildings.honeywell.com)  
[customer.honeywell.com](http://customer.honeywell.com)

**Honeywell**